



LIFETIME

kompostér DOUBLE



model 60072

návod na montáž a údržbu

Pro pomoc s montáží nebo objednání náhradních dílů volejte náš český HOT LINE 739-661-428

Bezpečnostní pokyny

- **Důležité! Před montáží si nejdříve až do konce přečtěte tento manuál.**
- Zkontrolujte si ihned po převzetí produktu, zda balení obsahuje všechny části a součástky.
- Před tím, než začnete kompostér stavět, si rozdělte a identifikujte všechny části a součástky pomocí seznamu částí v tomto dokumentu. Pokud nějaký díl chybí, **kompostér nestavte** a kontaktujte náš HOT LINE.
- Při montáži používejte ochranné pomůcky a dodržujte předpisy bezpečnosti práce.
- Správná a úplná montáž, užití a kontrola jsou důležité ke snížení rizika nehody nebo poranění.
- Kompostér je možné používat pouze jako kompostér. Jakékoliv jiné použití je v rozporu s návodem na použití a výrobce v tomto případě neručí za bezpečnost výrobku.
- Řiďte se pečlivě všemi upozorněními a výstrahami.
- Kompostér musí být postaven na rovném povrchu.
- Během sezóny i před ní kontrolujte, zda jsou veškeré spoje dostatečně utažené.
- Většina poranění je způsobena špatným použitím nebo nedodržením pokynů v manuálu. Dbejte pokynů při používání tohoto výrobku.
- Kompostér nesmí obsluhovat nebo jinak užívat děti !! Nebezpečí poranění.

Čištění a údržba

Pokud budete dodržovat následující instrukce, bude vám výrobek sloužit mnoho let k vaší spokojenosti. Panely z polyetylénu jsou odolné vůči nečistotám a rozpouštědlům. Většinu nečistot lze odstranit jemným mýdlovým roztokem a měkkou houbičkou. Drsné čisticí materiály by mohly plasty poškrábat, proto nejsou doporučovány. Velice jemným smirkovým papírem lze opravit škrábance nebo koroze na kovu, použijte ochranný sprej proti rzi jako podklad a nakonec použijte bezbarvý lak ve spreji s vysokým leskem. Nepoužívejte a ani neskladujte zdroje tepla uvnitř nebo poblíž kompostéru.

Prodloužená smluvní záruka

Výrobce si vyhrazuje právo na změnu reklamace, jestliže budou části nedostupné nebo zastaralé.

1. Výrobce poskytuje původnímu kupujícímu prodlouženou smluvní záruku na kompostéry **po dobu 5 let** od data nákupu. Defekty jsou definovány jako závada, která omezuje použití produktu. Defekty způsobené nesprávným použitím nebo nedbalostí do záruky nespádají. Záruku není možné uplatnit ani na defekty způsobené nesprávnou instalací, úpravami nebo nehodami. Také ji nelze použít v případě poškození způsobeného vandaly, korozí, „vyšší mocí“, pojistnou událostí nebo jinými událostmi mimo kontrolu továrny.
2. Tato záruka je nepřenosná a je výslovně omezená k opravě nebo výměně poškozeného produktu. Pokud je výrobek poškozen v termínu záruky, výrobce opraví nebo vymění poškozené části zdarma. Náklady na odeslání z a do prodejny v tom zahrnuté nejsou a je to na odpovědnosti kupujícího. Práce a podobné výlohy na přepravu, instalaci nebo výměnu výrobku nebo jeho částí nejsou zahrnuté do záruky.
3. Do záruky není zahrnuto poškrábání nebo odření výrobku při běžném používání. Navíc nejsou do záruky zahrnuté defekty vyplývající z úmyslného poškození, nedbalosti, nerozumným užíváním.
4. Zodpovědnost za náhodné nebo následné škody je vyloučena v rozsahu povoleným zákonem. Ačkoli je celé příslušenství vyrobeno s nejvyšším stupněm bezpečnosti, nelze vyloučit možnost poranění. Uživatel přebírá zodpovědnost za veškerá nebezpečí úrazu, plynoucí z užívání tohoto produktu
5. Tento produkt není určen pro komerční účely, výrobce při takovém užití nepřebírá zodpovědnost. Komerční používání povede ke zrušení záruky.

BEZPEČNOSTNÍ UPOZORNĚNÍ:

Upozorňujeme na fakt, že v ojedinělých případech (stejně jako při jakémkoliv jiném kompostovacím procesu) může v extrémních případech dojít biologickému zahoření obsahu kompostéru. Vzniká tak riziko potencionálního požáru kompostéru, případně okolí.

Umístěte proto raději kompostér na takovém bezpečném místě, kde ani v případě biologického zahoření (naprosto ojedinělá, ale možná situace) nevznikne riziko škody.

Biologické zahoření je fyzikálním jevem, který výrobce nemůže nijak ovlivnit ani mu nijak předejít. Za případné škody vzniklé biologickým zahořením, tak výrobce ani prodejce nemohou zodpovídat.



SAFETY INSTRUCTIONS



FAILURE TO FOLLOW THESE WARNINGS MAY RESULT IN SERIOUS INJURY OR PROPERTY DAMAGE AND WILL VOID WARRANTY.

5P FOTVSF TBGFUZ EP OPU BUUFNQJ UP BTTFCMF UJT QSPEVDU XJUIPVU GPMMPXJOH UIF JOTUSVDUJPOT DBSFGVMZ \$IFDL FOUJSF CPY BOE JOTJEF BMM QBDLJOH NBUFSJBM GPS QBSUT BOE PS BEEJUJPOBM JOTUSVDUJPO NBUFSJBM #FGPSF CFHJOOJOH BTTFCMZ SFBE UIF JOTUSVDUJPOT BOE JEFUJGZ QBSUT VTJOH UIF IBSEXBSF JEFUJmFS BOE QBSUT MJTU JO UJUT EPDVNFOU 1SPQFS BOE DPNQMFUF BTTFCMZ VTF BOE TVQFSWJTJPO BSF FTTFOUJBM UP SFEVDF UIF SJTL PG BDDJEFUO PS JOKVSZ

t5XP DBQBCMF BEVMUT BSF SFRVJSFE GPS BTTFCMZ

Most injuries are caused by misuse and/or not following instructions. Use caution when using this product.



INSTRUCCIONES DE SEGURIDAD



EL INCUMPLIMIENTO DE SEGUIR ESTAS ADVERTENCIAS PUEDE RESULTAR EN LAS LESIONES GRAVES O EL DAÑO A LA PROPIEDAD Y ANULARÁ LA GARANTÍA.

1BSB BTFHVSBS MB TFHVSJEBO OP JOUFOUF EF BSNBS FTUF QSPEVDUP TJO TFHVSJ EFUFOJEBNFOUF MBT JOTUSVDDJPOFT *OTQFDJPOF MB DBKB FOUFSB Z UPEB MB NBUFSJB EF FNCBMBKF QBSB MBT QBSUFT Z P NBUFSJB BEJDJPOBM "OUFT EF DPNFOJBS FM BSNBEP MFB MBT JOTUSVDDJPOFT F JEFUJmRVF MBT QBSUFT VTBOEP FM *EFOUJmDBEPS EFM IFSSBKF Z MB -JTUB EF QJFBT FO FTUF EPDVNFOUP &M BSNBEP QSPQJP Z DPNQMFUF FM VTP Z MB TVQFSWJTJRO TPO FTFODJBMFT QBSB MB PSJFOUBDJRO QSPQJP Z QBSB SFEVDJS FM SJFTHP EF BDDJEFUOFT Z MFTJPOFT

t%PT BEVMUPT DPNQMFUOFT TPO SFRVJSJEPT QBSB FTUF BSNBEP

La mayoría de las lesiones son causadas por el uso erróneo y/o el incumplimiento de seguir las instrucciones. Tenga cuidado al usar este cobertizo.



INSTRUCTIONS DE SÉCURITÉ



LA NON-OBSERVATION DE CES AVERTISSEMENTS PEUT ENTRAÎNER EN CONSÉQUENCE DES BLESSURES SÉRIEUSES OU L'ENDOMMAGE À LA PROPRIÉTÉ ET ANNULER LA GARANTIE.

1PVS BTTVSFS WPUSF TDDVSJUO O BUJFOUF QBT EF NPOUFS DFU DMNFOU TBOU TVJWSF BUJFOUJWFNFOU MFT JOTUSVDUJPOT 7DSJmF MFT CPDUFT FOUJNSFT FU M JOUJJSJVS EF UPVU MF NBUJJSJFM QPVS MFT QJNDFT FU PV NBUJJSJFM E JOTUSVDUJPO BEEJUJPOOFM *WBOU EF DPNNFODFS MF NPOUBHF MJTF MFT JOTUSVDUJPOT FU JEFUJmF MFT QJNDFT FO VUJMTBOU M *EFOUJmDBUJVS E BDDFTTPJSFT FU MB -JTUF EF QJNDFT EBOT DF EPDVNFOU -F NPOUBHF QSPQSF FU DPNQMNUF FU MB TVQFSWJTJPO TPOU FTTFOUJMT QPVS SDEVJSF MF SJTRVF EFT IBTSET PV EFT CMFTTSFT

t%FVY BEVMUFT DBQBCMFT TPOU SFRVJT QPVS NPOUFS DFU DMNFOU

La plupart des blessures sont causées par l'abus et/ou par ne suivre les instructions. Faites attention lorsque vous utilisez cet abri.



INSTRUÇÕES DE SEGURANÇA



DEIXAR DE SEGUIR ESTAS ADVERTÊNCIAS PODERÁ PROVOCAR LESÕES GRAVES OU DANOS À PROPRIEDADE E ANULARÁ A GARANTIA.

1BSB NBOUFS B TFHVSBOIB OIP UFOUF NPOUBS FTUF TJTUFNB TFN TFHVSJ BUFOUBNFOUF BT JOTUSVUFT *OTQFDJPOF UPEB B DBJYB F P DPOUFTEP EP NBUFSJBM EF FNCBMBHFN QBSB MPDBMJBS BT QFIBT F PV NBUFSJBT DPN JOTUSVUFT BEJDJPOBT "OUFT EF JOJDBS B NPOUBHFN MFJB BT JOTUSVUFT F JEFUJmRVF BT QFIBT VTBOEP F JEFUJmDBEPS EBT GFSSBHOT F B MJTUB EF QFIBT FYJTUOFT OFTUF EPDVNFOU O VTP B NPOUBHFN F B TVQFSWJTJP BEFRVBEPT F DPNQMFUPT TIP GVOEBNFOUJTB QBSB EJNJOVJS P SJTDP EF BDJEFUO PV MFTIP &YJTUF VNB HSBOEF QSPCBCJMJEFEF EF MFTIP HSBWF TF OIP TF NPOUBS NBOUJWFS F PQFSBS FTUF TJTUFNB EF NPEP BEFRVBEP

t3FDPNFOEB TF B QBSUJJDJQBIP EF EPJT BEVMUPT DBQBDJUBEPT OB NPOUBHFN

A maioria das lesões decorre do uso inadequado e/ou de não seguir as instruções. Tome cuidado ao usar este sistema.



啖嫖



思口爆m嫖口嫖 佬奴口衣 鸞傭 口屈善nV::口z口 尸::ǎ口

睇ǎ眺<被口g 焗嫖天v 婬口歇姪口 思口嫖哩膊襖w殍s地埴鸞墅s擗尻勃q簪>^ h 口口姪s 墅口被曝g B口i i 口I 句~被嫖
啖口B<口嫖←鸞墅口↑焗娼嫖嫖^ ǎ菴烽匹B口被僕B三媽馮曝B焗 7H輻嫩曝B<喉輻口g 口勃被鸞墅焗喉輻ǎ菴穀 | 口覷讀牌
矛埴 口被焗x^ 養口k剔- 晒口 口sx純曝q墅佞歇姪口墅焗黏ǎ口i i 口I g 候ǎ喉口牌姪褫荼 鸞傭 口被檀桐晒 嫖

t!水嫖菲S 嫖口S佬= 佞地埴鸞墅s

:: 勳 口牌菲吼嫩菴口)0口*!思口 嫖嫖s !ǎ菴ǎ菴曝q墅佞嗲天口 ǎ !

U.S. and Canada customers ONLY

IF ASSISTANCE IS NEEDED, DO NOT CONTACT THE STORE!

CALL OUR CUSTOMER SERVICE DEPARTMENT at 1 (800) 225-3865

)0634 BN UP QN .POEBZUISPVHI'SJEBZ .PVOUBJO4UBOEBSE5JNF
\$BMM PS WJTJU PVS 8FC TJUF GPS 4BUVSEBZ IPVST
PS DVTUPNFST PVUTJEF UIF 6 4 PS \$BOBEB QMFBTF DPOUBDU UIF TUPSF GPS BTTJTUBODF

Clientes de los E.U.A. o de Canadá SOLAMENTE

SI NECESITA ASISTENCIA, NO CONTACTE LA TIENDA!

LLAME A NUESTRO DEPARTAMENTO DE SERVICIOS A CLIENTES AL 1.800.225.3865

)03"4 MVOFT B WJFSOFT)/3
-MBNF P WJTJUF OVFTUSB QČHJOB FO *OUFSOFU QBSB MBT IPSBT EF TČCBEP
1BSB MPT DMJFOUFT BGVFSB EF MPT & TUBEPT 6OJEPT P EF \$BOBEČ QŘOHBTf FO DPOUBDUP DPO MB WJFOEB QPS GBWPS

Clients des États-Unis et du Canada SEULEMENT

SI VOUS AVEZ BESOIN D'ASSISTANCE, NE CONTACTEZ PAS LE MAGASIN !

APPELEZ NOTRE DÉPARTEMENT DE SERVICE À LA CLIENTĀLE AU 1.800.225.3865

)&63&4 MVOEJ WFOESFEJ)/3
"QQFMF[PV SFOEF[WPVT VOF WJTJUF Ę OPUSF TJUF 8FC QPVS PCUFOJS MFT IFVSFT EF TBNFEJ
\$MJFOUT BV EFIPST EFT ,UBUT 6OJT PV EV \$BOBEB WFWJMMF[DPOUBDUFS MF NBHBTJO QPVS PCUFOJS BTTJTUBODF



1(800)225-3865



18+

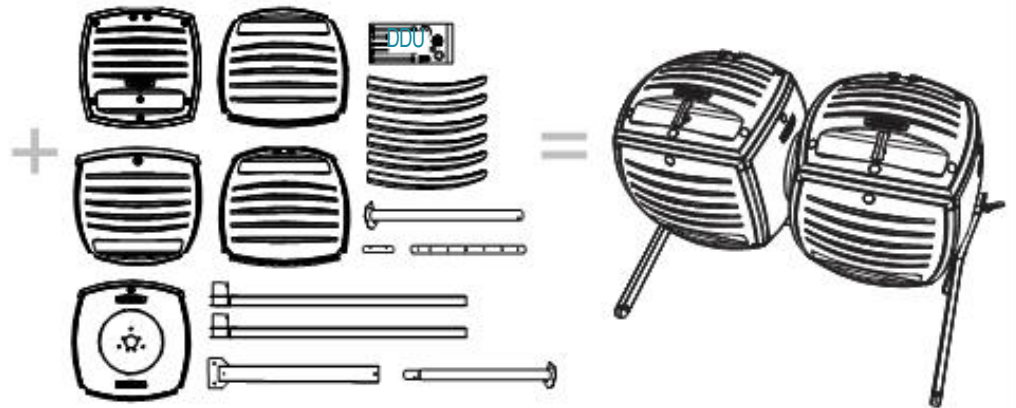

3/8" (9,5 mm)

7/16" (11,1 mm)

1/2" (12,7 mm)



(1)



(2)



(2)



(1)



(1)



(1)



(1)



(3)



DBV Y



DBR Y



DBS Y



DCX Y



DBT Y



DBU Y



DEI Y



DEL Y



DEK Y



DCV Y

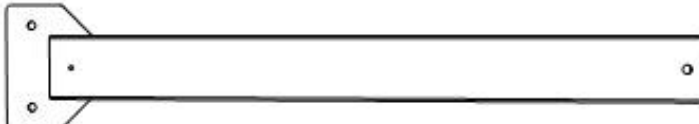

DEJ Y



DEM Y



DEH



DDO Y



DDR Y



DDG Y



DDK Y

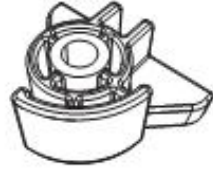

DDP Y



DDQ Y



DEY Y



DDS Y

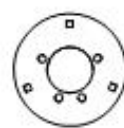

DCW Y



DDC Y

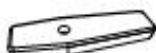

DDJ Y

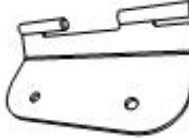

DDH Y



DDI Y

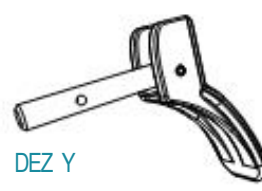

DEZ Y



AAH Y

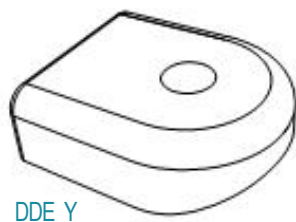

DDE Y



DEO Y



DDW Y



BIN Y

DDU

1

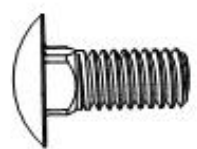

BIR Y



BBO Y



BTK Y



AAN Y

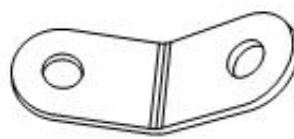

DEG Y



BHO Y

2

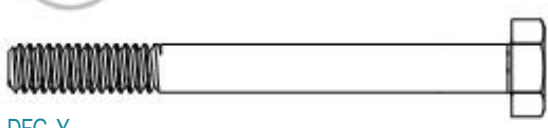

DFG Y

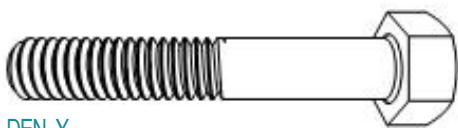

DEN Y

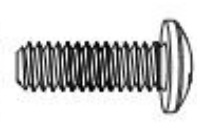

BFY Y



BHJ Y



ADJ Y



AAN Y

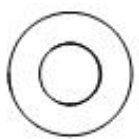

BHO Y



3



DDL Y

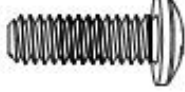

BFY Y



DDN Y

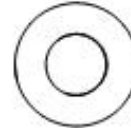

BHO Y

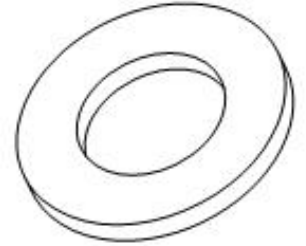

DDM Y



AAN Y



ADJ Y



1



BBO Y

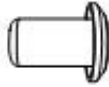

BTK Y



BIR Y



AAN Y

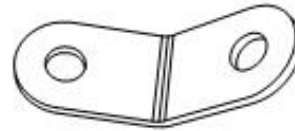

DEG Y



BHO Y



DDW Y



DCW Y



DCX Y



DBU Y



DBS Y



DBV Y



DBT Y



DBR Y



1/2" (12,7 mm)



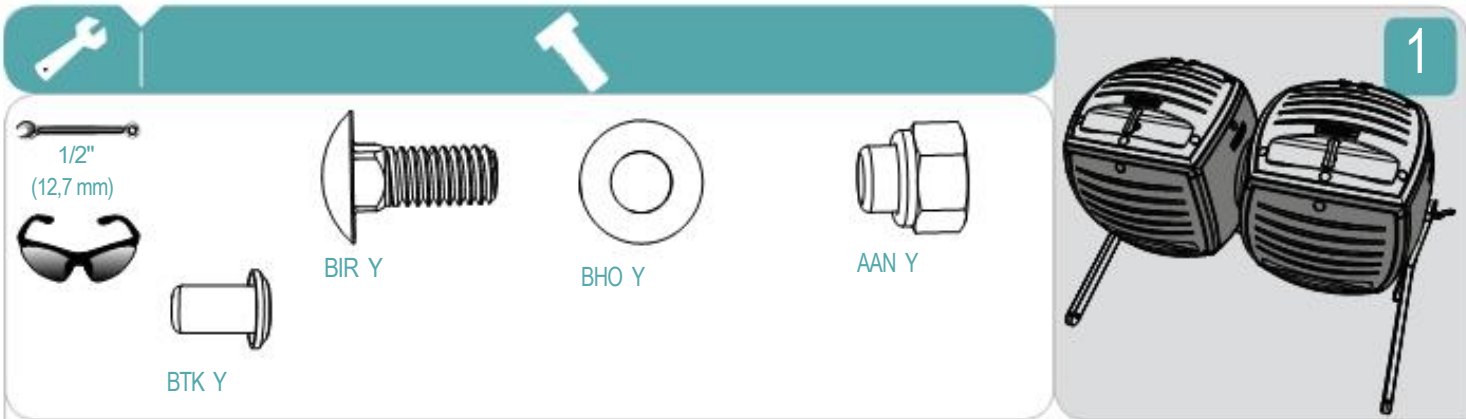

1.1

Tento krok zopakujte se všemi 12 panely.

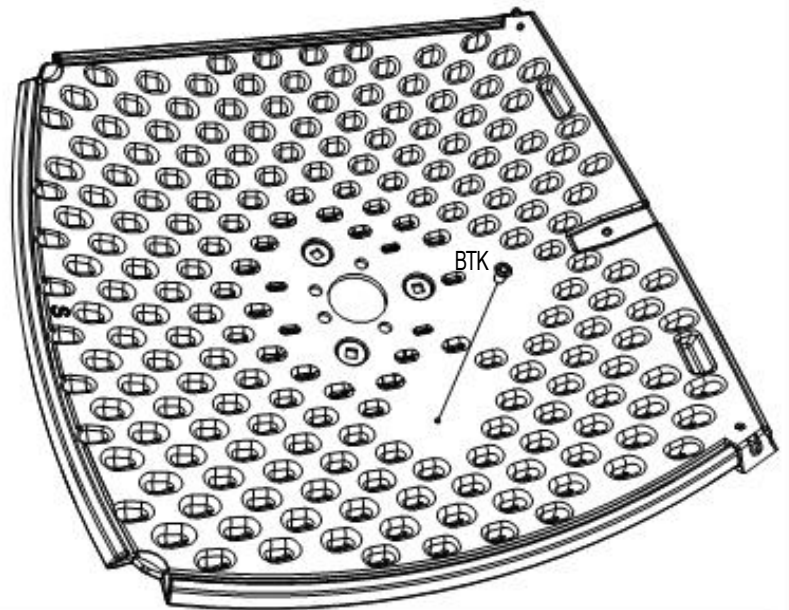

1.2

Tento krok zopakujte také u druhého bočního panelu DBT.

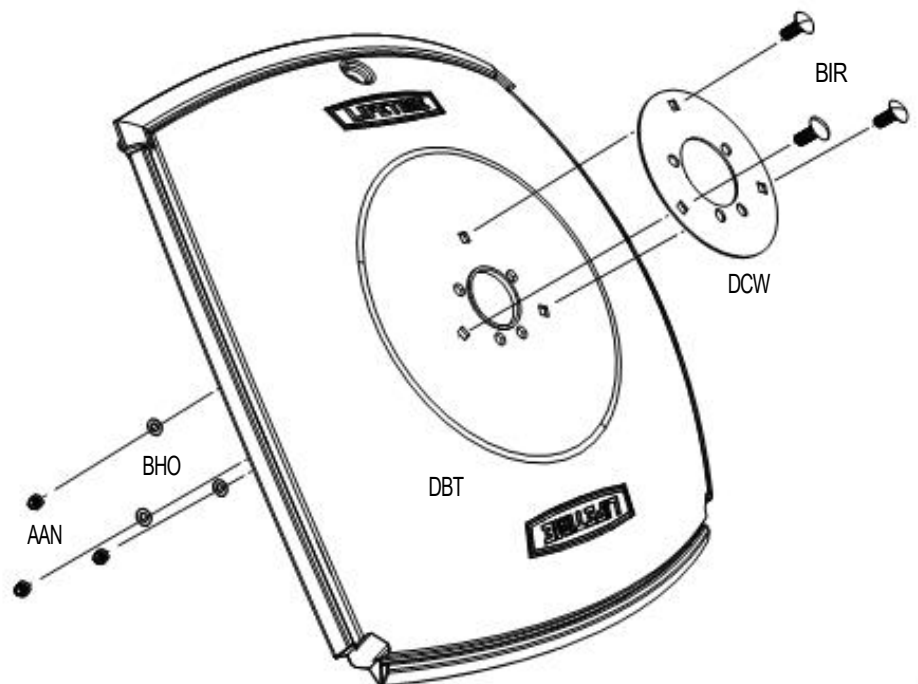



1



1.3



DBV

Nasuňte konektor panelu DCX na spodní zadní panel DBV – všimněte si směru.
Možná bude potřeba lehce poklepat gumovou palicí na konektor, aby se zasunul na místo.

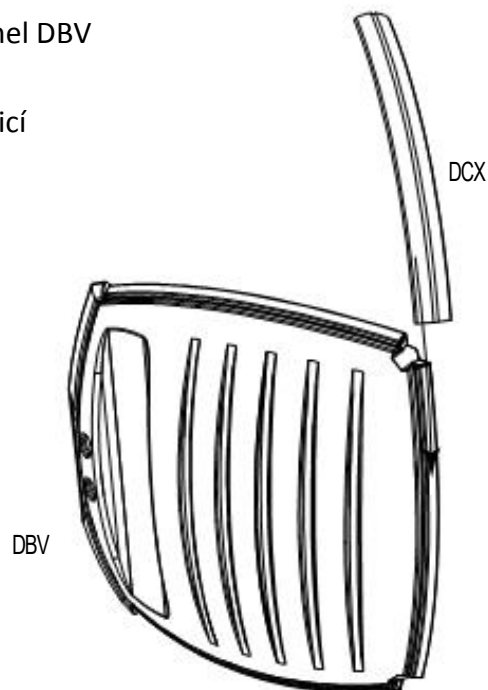

1.4



DBS

Zasuňte horní okraj spodního panelu DBS – všimněte si směru – do konektoru panelu.

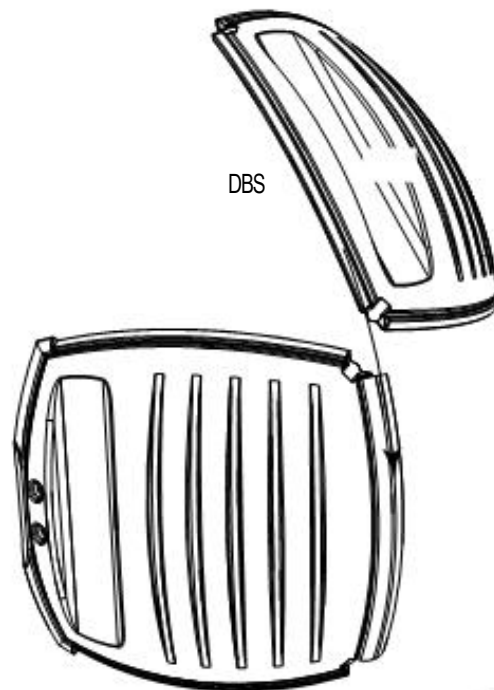



1



1.5

Nasuňte konektor panelu DCX na bok zadního panelu DBV – všimněte si směru.
Možná bude potřeba lehce poklepat gumovou palicí na konektor, aby se zasunul na místo.

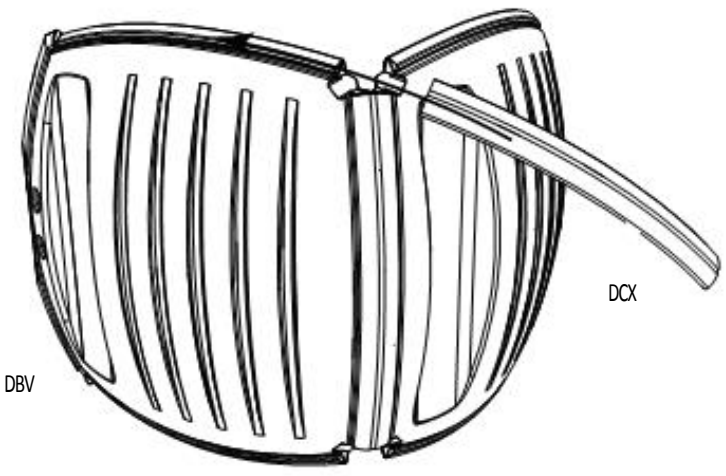

1.6



DBT

Zasuňte boční okraj postranního panelu DBT na konektor panelu - všimněte si směru.
Možná bude potřeba lehce poklepat gumovou palicí na konektor, aby se zasunul na místo.

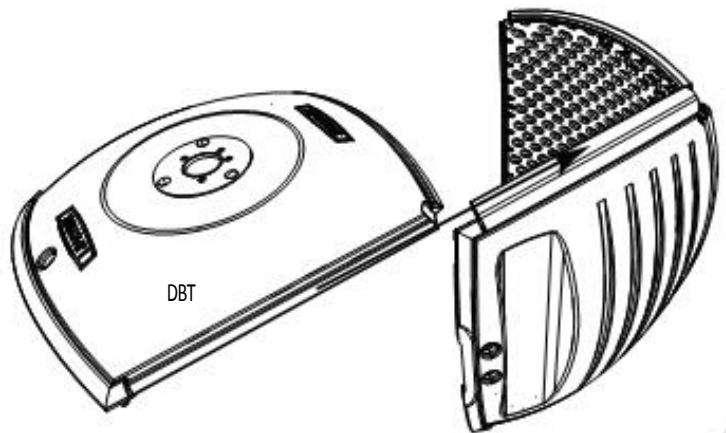



1.7

Nasuňte konektor panelu DCX na okraje spodního a bočního panelu.
Možná bude potřeba lehce poklepat gumovou palicí na konektor, aby se zasunul na místo.

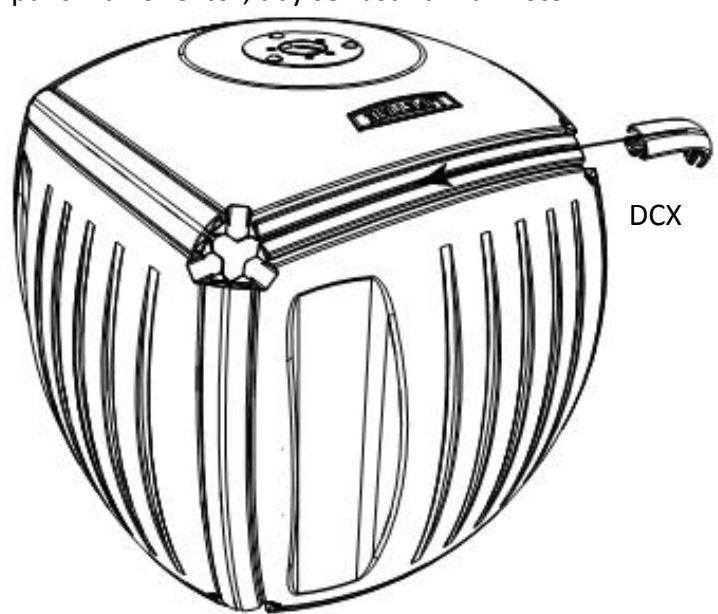

1.8

Nasuňte konektor panelu DCX na okraj zadního panelu.
Možná bude potřeba lehce poklepat gumovou palicí na konektor, aby se zasunul na místo.

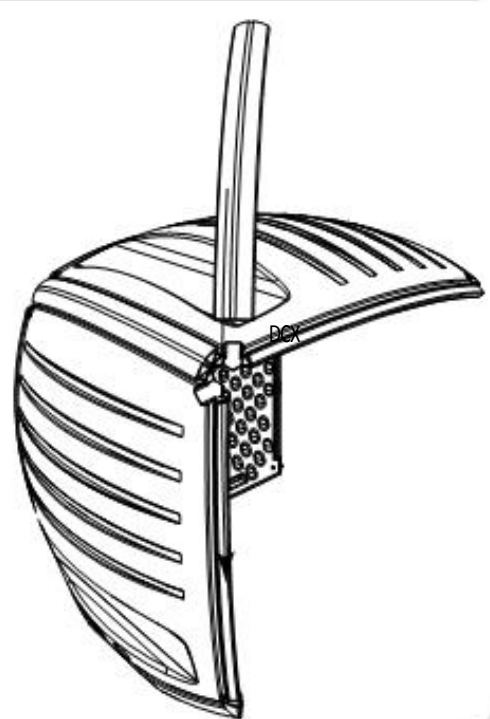



1.9



Zasuňte druhý boční panel DBT do konektoru umístěného na zadním panelu. Potom nasuňte konektor DCX přes boční a spodní panel. Možná bude potřeba lehce poklepat gumovou palicí na konektor, aby se zasunul na místo.

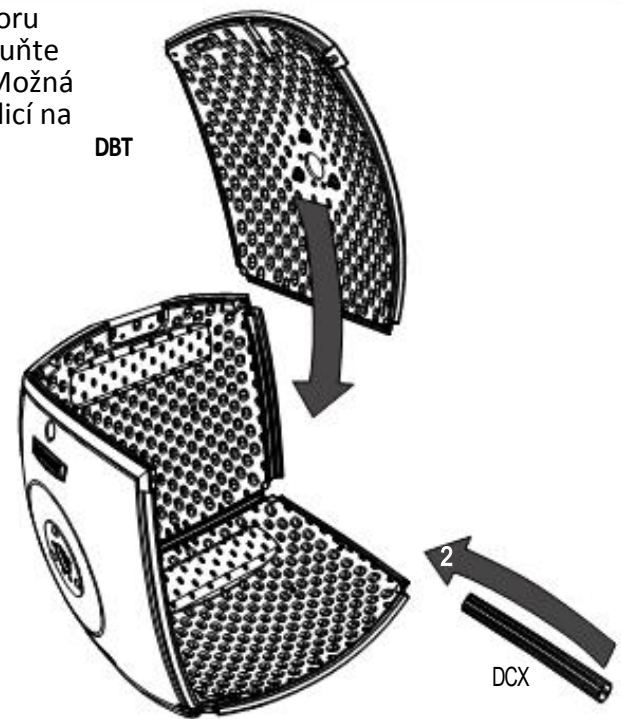

1.10

Nasuňte konektor DCX na okraj bočního panelu. Možná bude potřeba lehce poklepat gumovou palicí na konektor, aby se zasunul na místo.

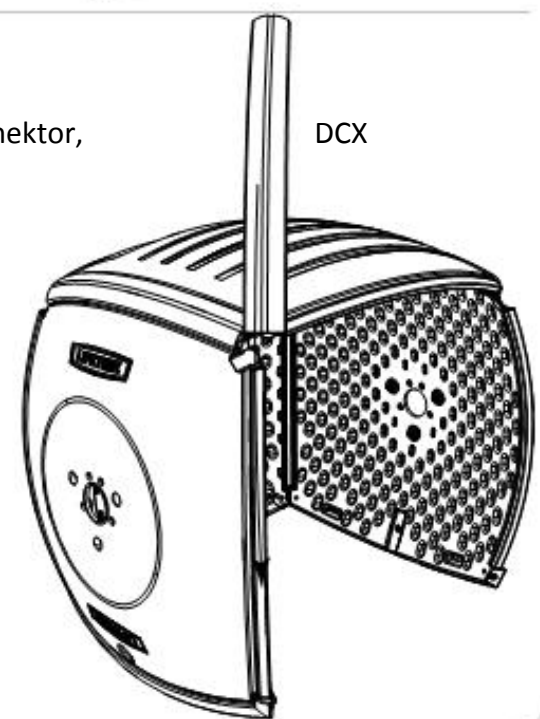



1.11



DBU

Zasuňte přední panel DBU do konektoru umístěného na bočním panelu – všimněte si směru. Možná bude potřeba lehce poklepat gumovou palicí na konektor, aby se zasunul na místo.

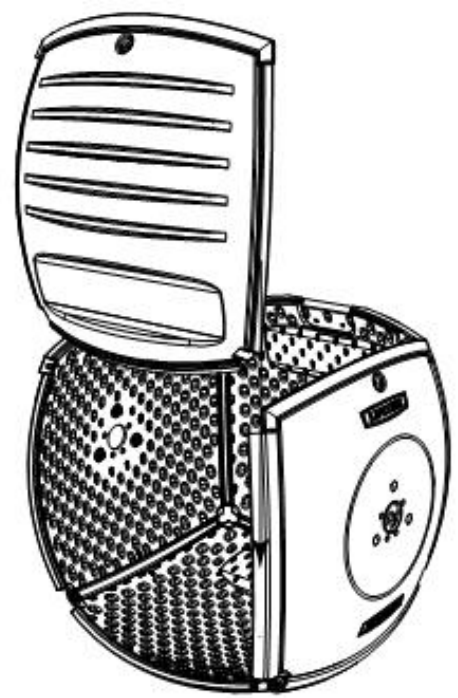

1.12

Nasuňte poslední dva konektory DCX na okraje panelů. Možná bude potřeba lehce poklepat gumovou palicí na konektory, aby se zasunuly na místo.

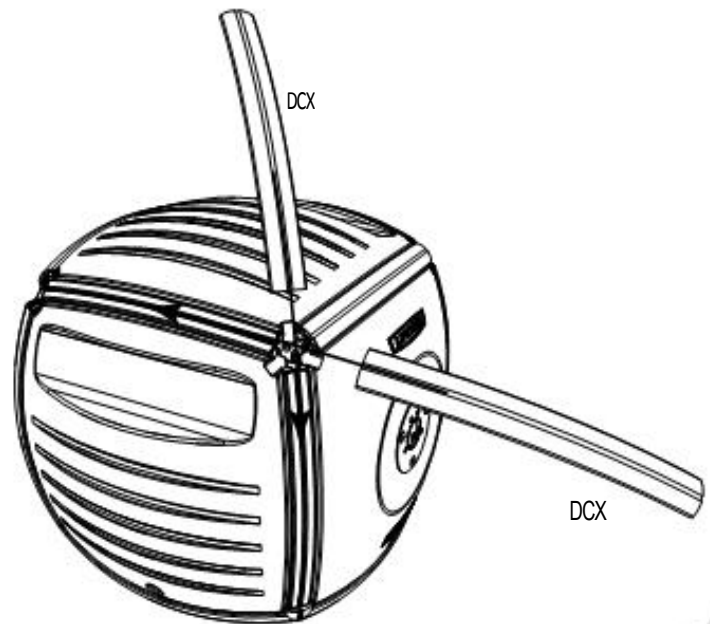

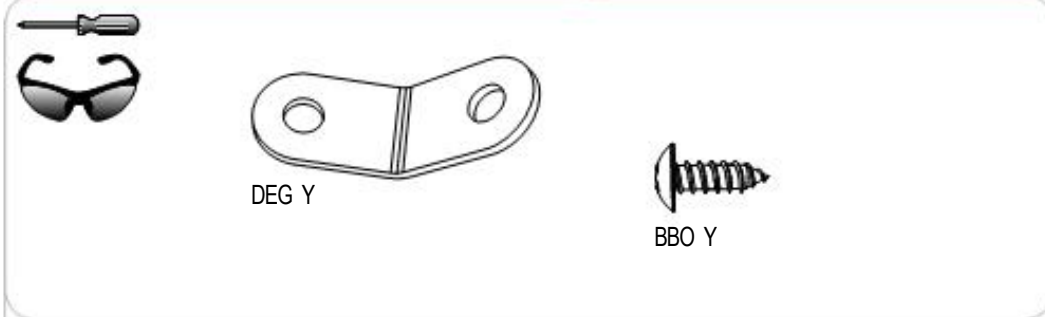

1.13

Tento krok zopakujte s každým vnitřním rohem.

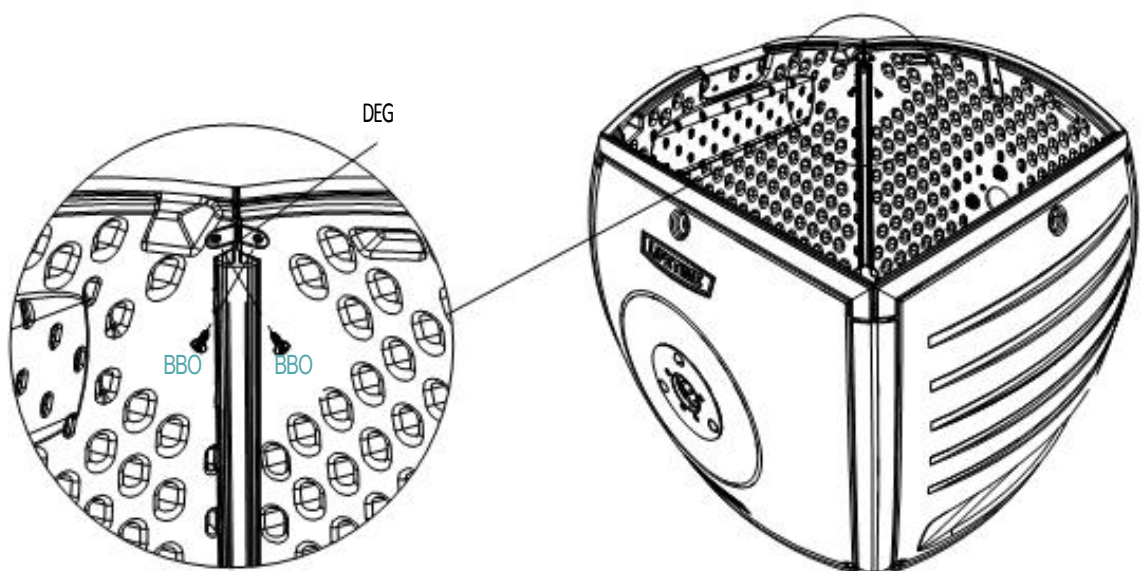

1.14

K připevnění každé rohové krytky DDW použijte šroubovák. Zopakujte kroky 1.2 – 1.14 s druhým bubnem.

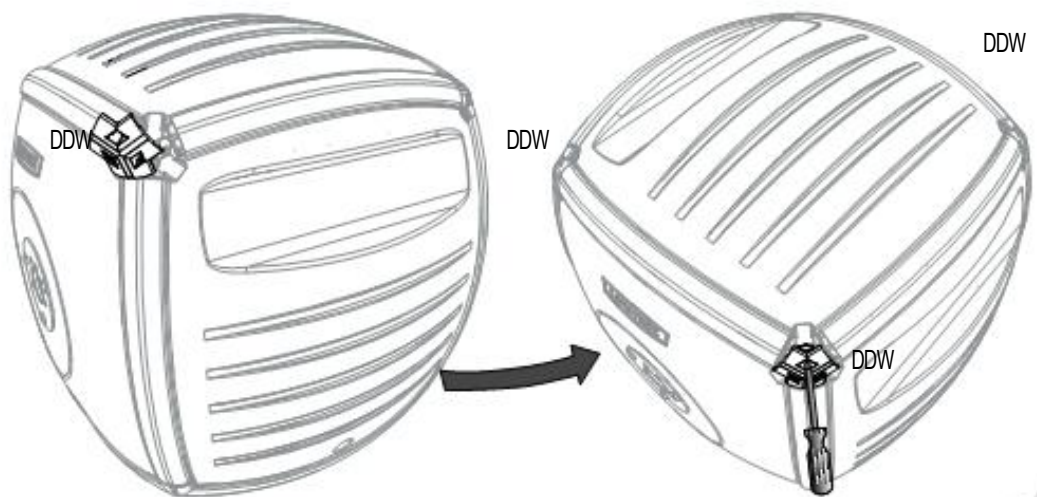



2

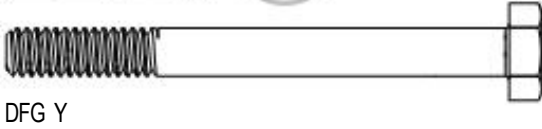

DFG Y

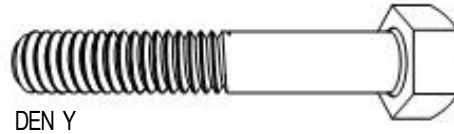

DEN Y

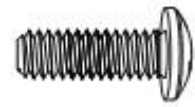

BFY Y



ADJ Y



AAN Y

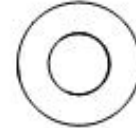

BHO Y



BHJ Y



DDJ Y

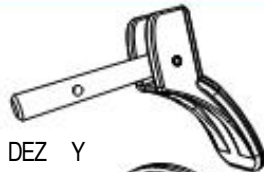

DEZ Y



DDH Y

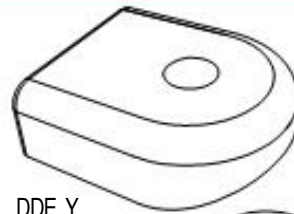

DDE Y



DDS Y



DDI Y



DDC Y



DEO Y

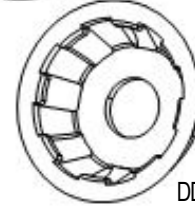

DDG Y



AAH Y



BIN Y



DEI Y

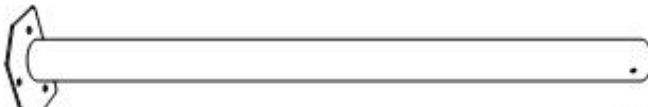

DEL Y



DEK Y



DCV Y



DEJ Y

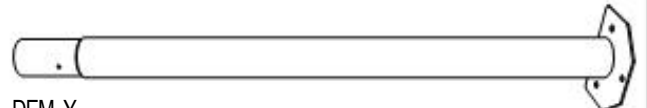

DEM Y



1/2" (12,7 mm) Y



7/16" (11,1 mm) Y





2



2.1

Zasuňte provzdušňovací trubku DCV do jednoho z bubnů tak, jak vidíte na obrázku.

Tento buben bude na pravé straně. S druhým bubnem zopakujte krok 2.1.

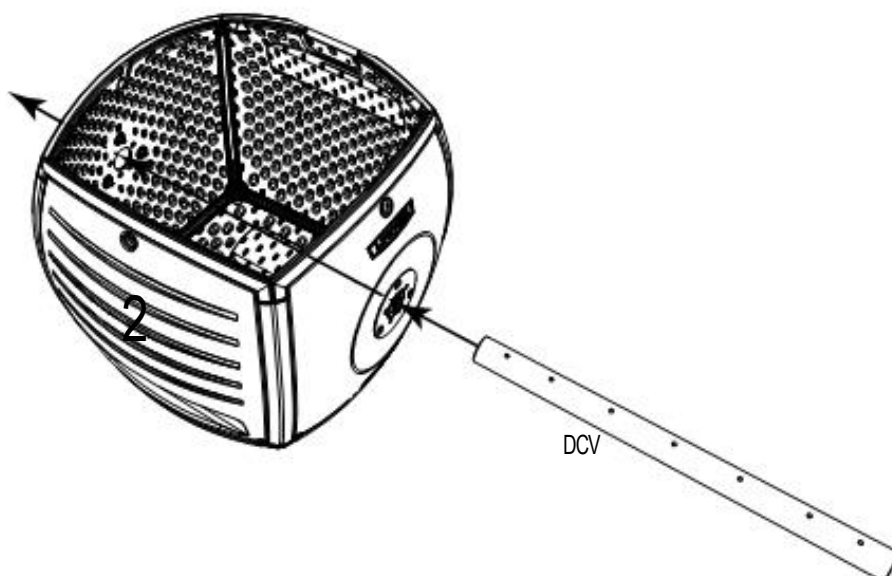

2.1

x2!

2.2

Vsuňte nátrubek DEK do provzdušňovací trubky a srovnejte otvory směřující nahoru a dolů.

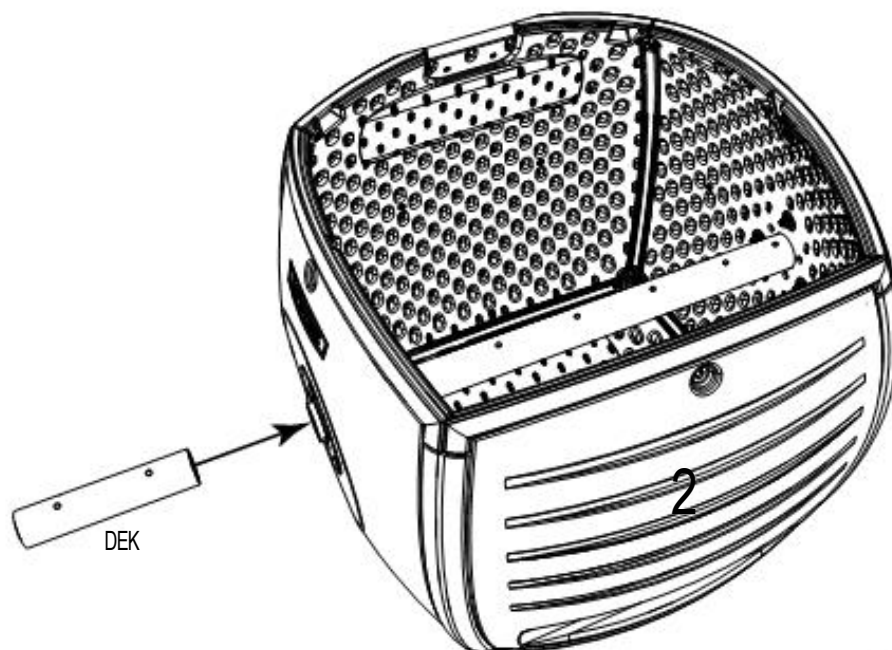

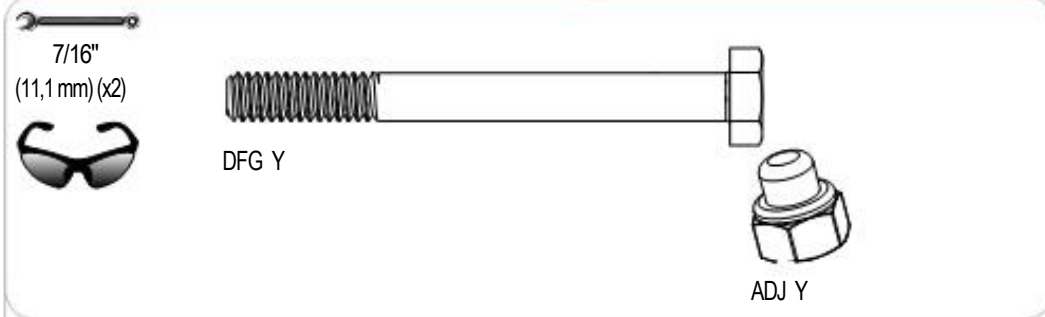

2.3

t Vložte šestihranný šroub DFG skrz otvory v poutku DDE uvnitř bubnu, v nátrubku a provzdušňovací tyči. Šroub utáhněte matkou ADJ.

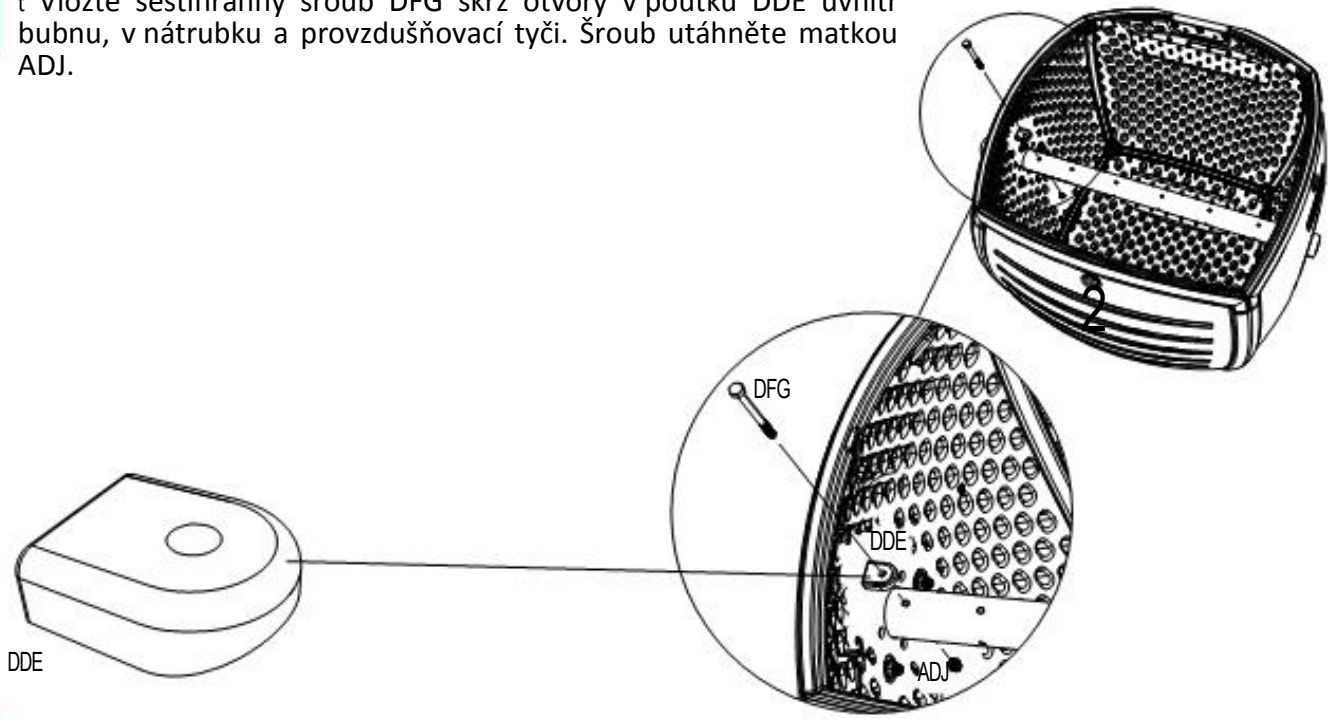

2.4

Nasuňte dvě podložky DDC přes nátrubek. Potom zasuňte na nátrubek další buben-ten bude nalevo.

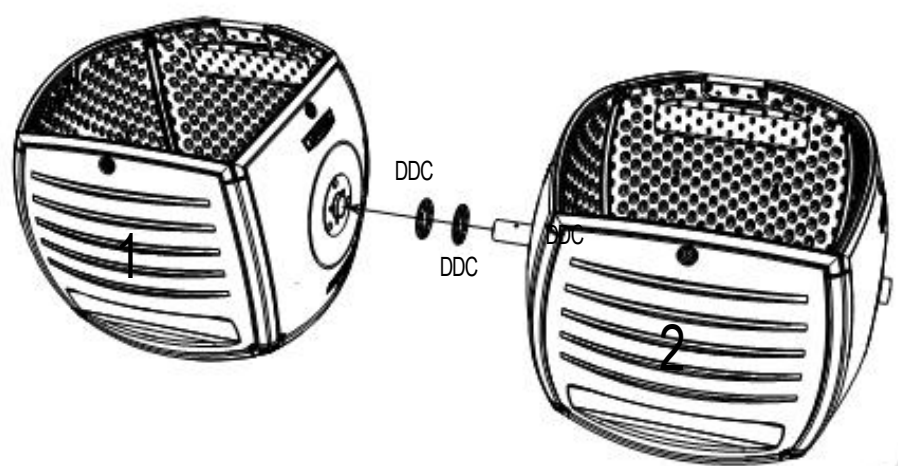

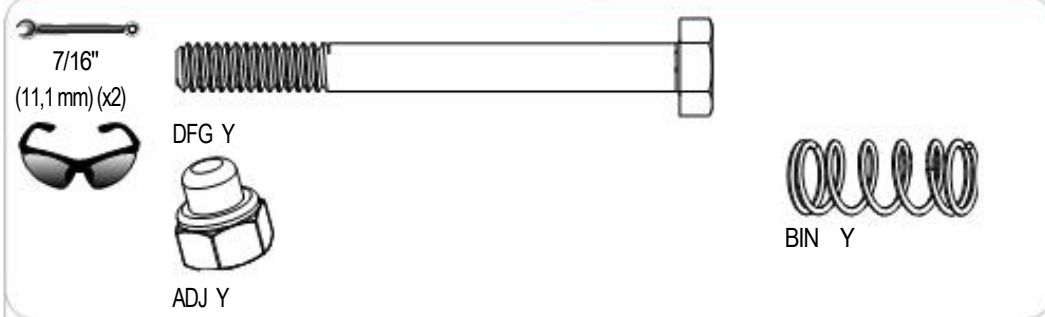

2.5

Vložte šestihranný šroub DFG skrz otvory ve výstupku DDE uvnitř bubnu, v nátrubku a provzdušňovací tyči. Šroub utáhněte matkou ADJ.

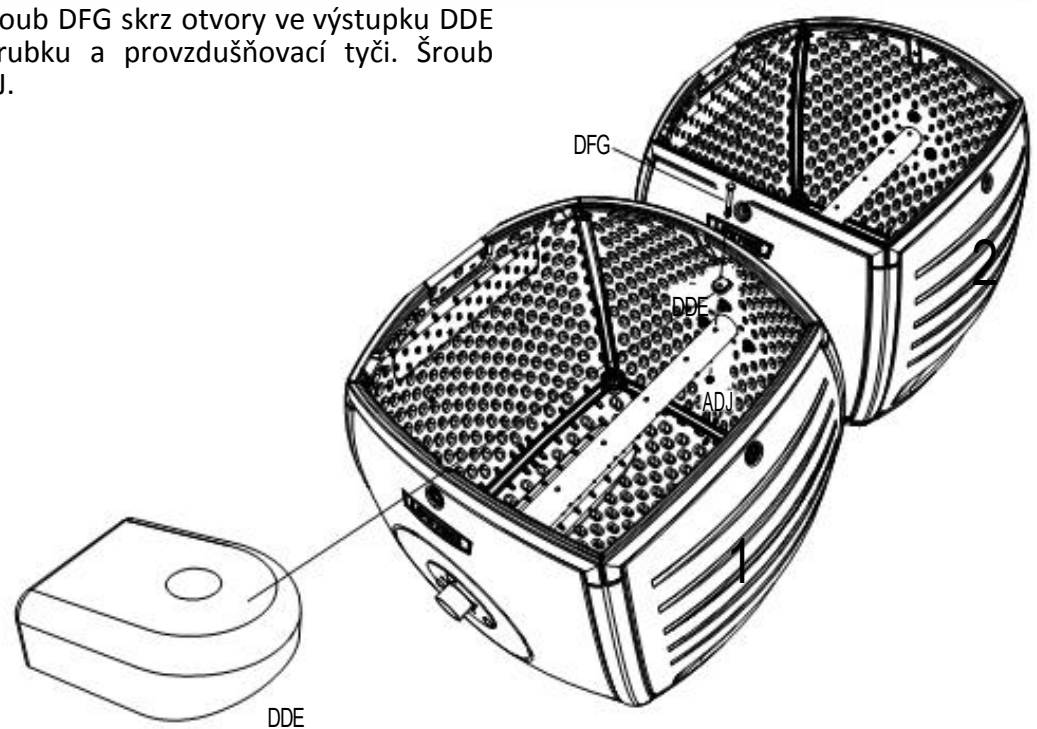

2.6

Vložte pružinku BIN do profilu jedné zadní nohy DEI, jak vidíte na obrázku. Tato noha bude na levé straně kompostéru.

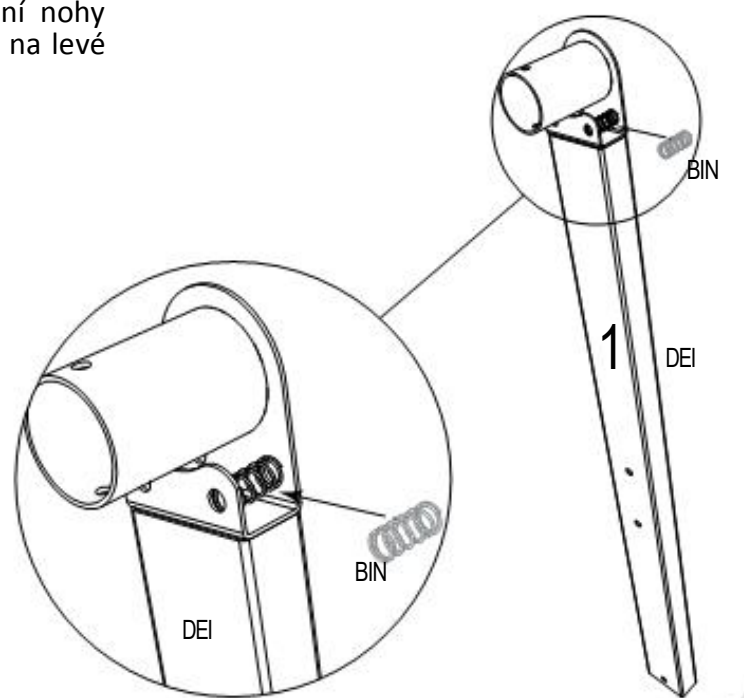



2.7

Vložte kolík DEZ skrz otvor v noze a pružince, jak vidíte na obrázku.

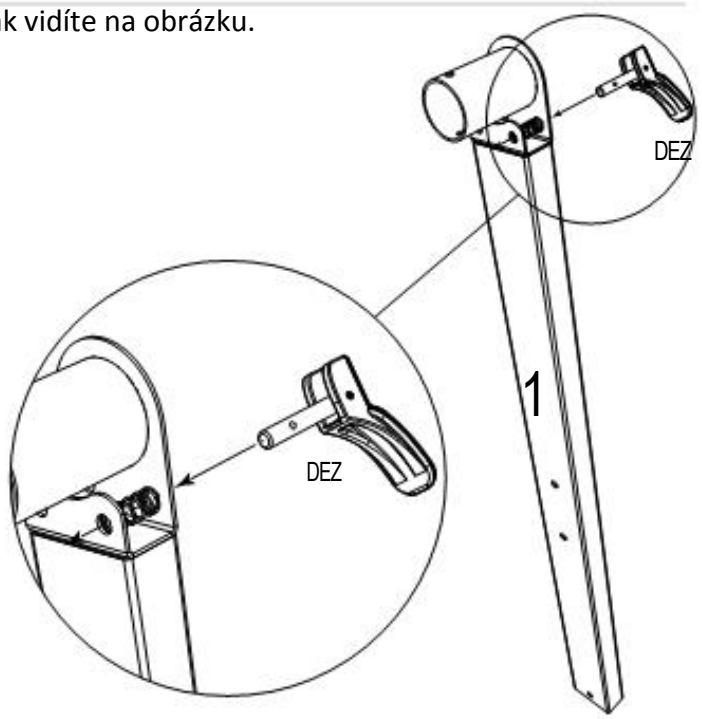

2.8

Vložte závlačku AAH skrz otvor v kolíku, jak vidíte na obrázku.

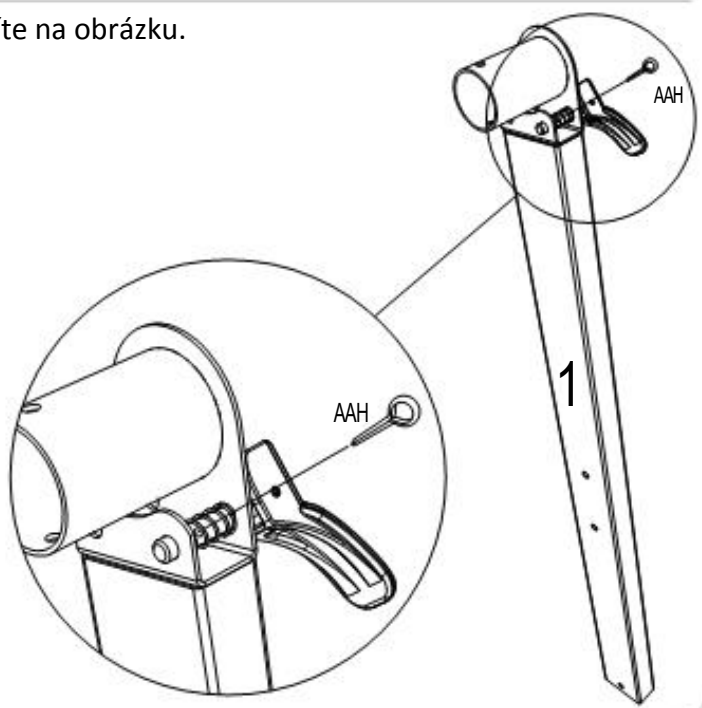



BIN Y



2

2.9

Ohněte konce závlačky směrem ven, aby držela na místě, jak vidíte na obrázku.



2.10

Nasměrujte profil druhé zadní nohy DEI tak, jak vidíte na obrázku a zopakujte krok 2.6. Tato noha bude na pravé straně kompostéru.

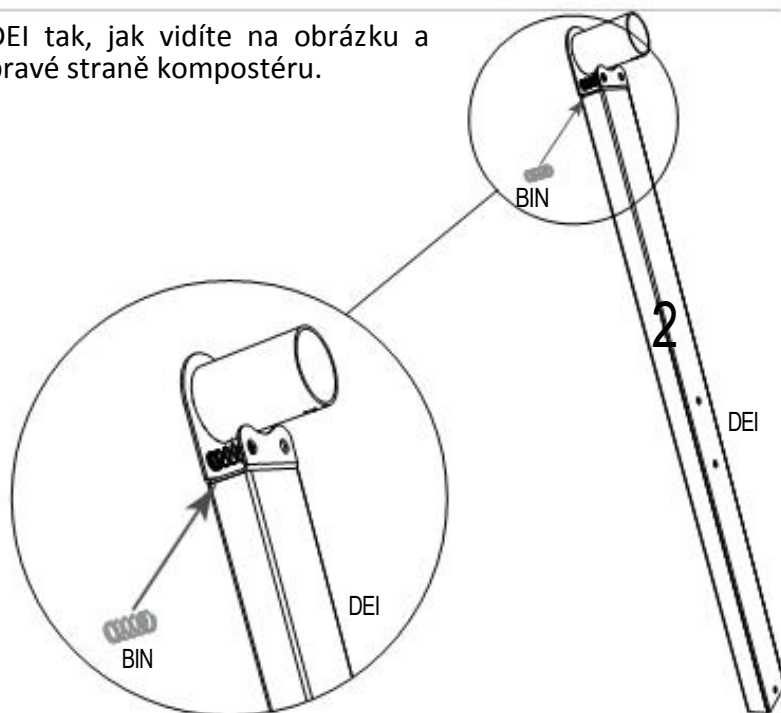



2.11

Zopakujte krok 2.7 s druhou zadní nohou podle obrázku.

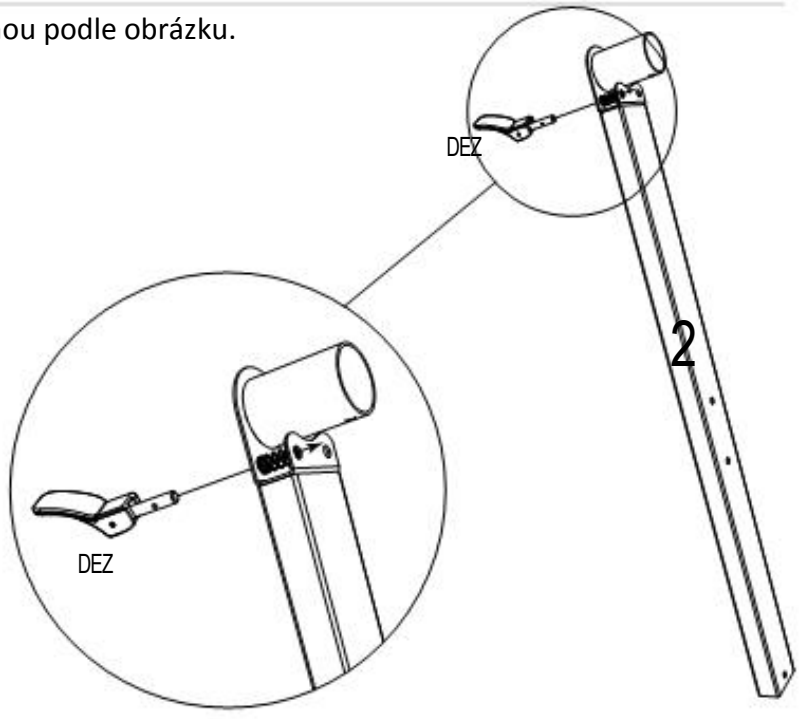

2.12

Zopakujte krok 2.8 s druhou zadní nohou podle obrázku.

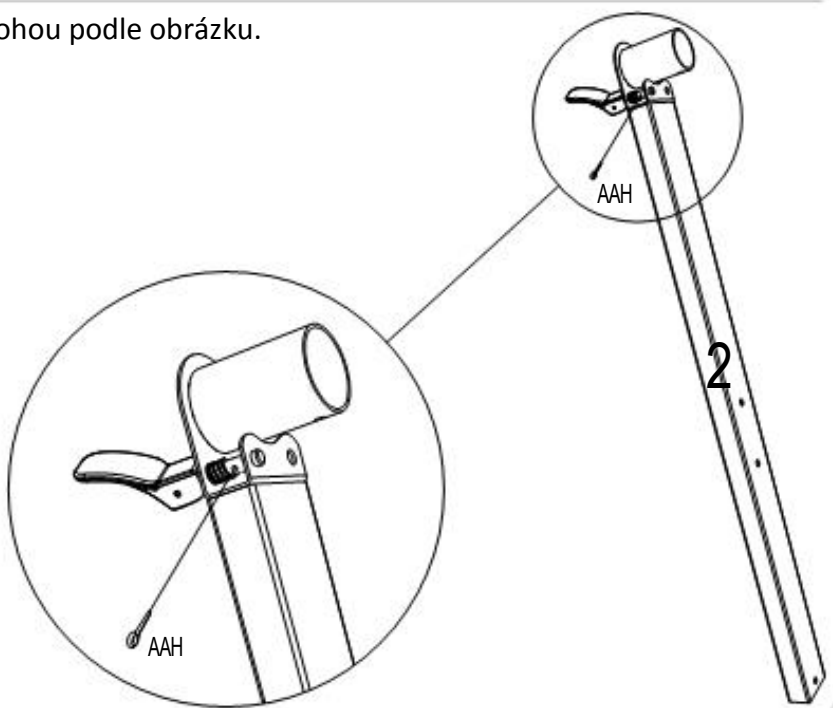



2



2.13

Zopakujte krok 2.9 s druhou zadní nohou podle obrázku.

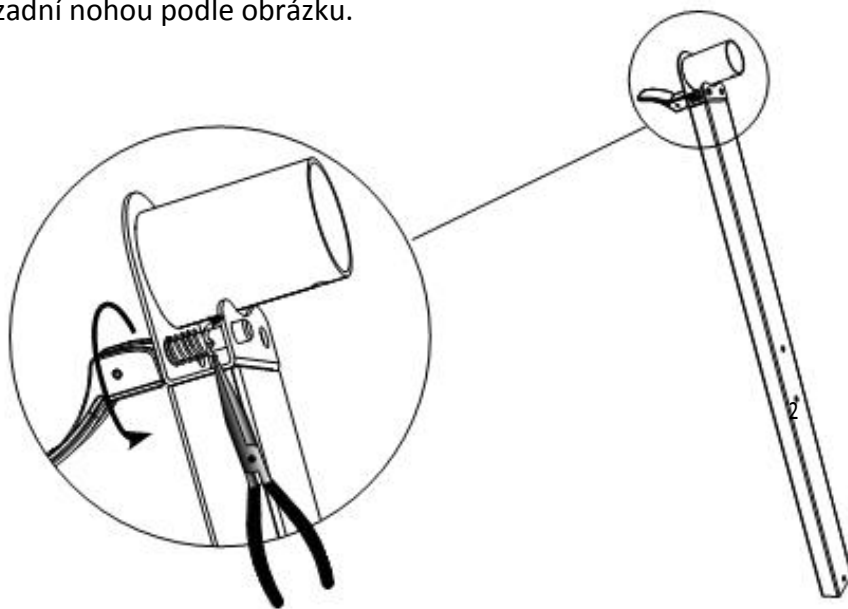

2.14

Zasuňte podložku DDC a první zadní nohu (složenou v krocích 2.6-2.9) na provzdušňovací trubici, jak vidíte na obrázku. Ujistěte se, že je vroubek v podložce zarovnaný s kolíkem.

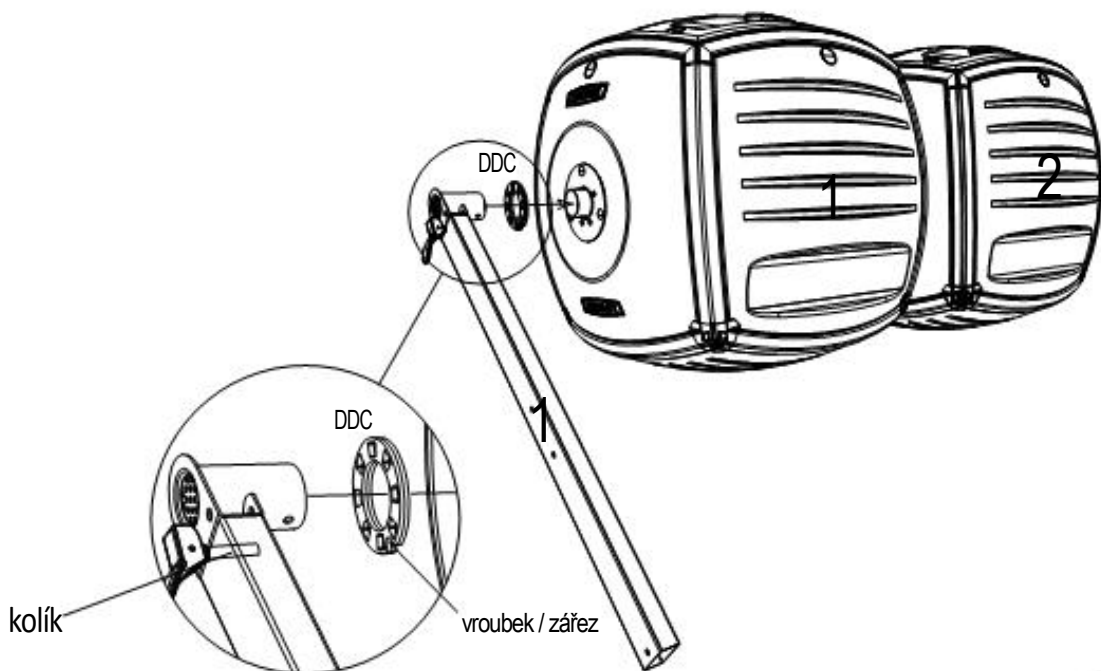

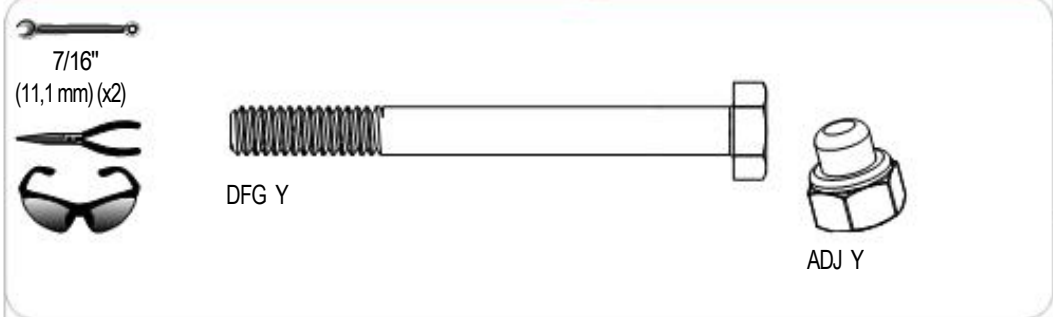

2.15

Upevněte zadní nohu (z kroků 2.6-2.9) k levé straně bubnů potřebným materiálem.

Tento krok zopakujte také u druhé zadní nohy na pravé straně bubnů.

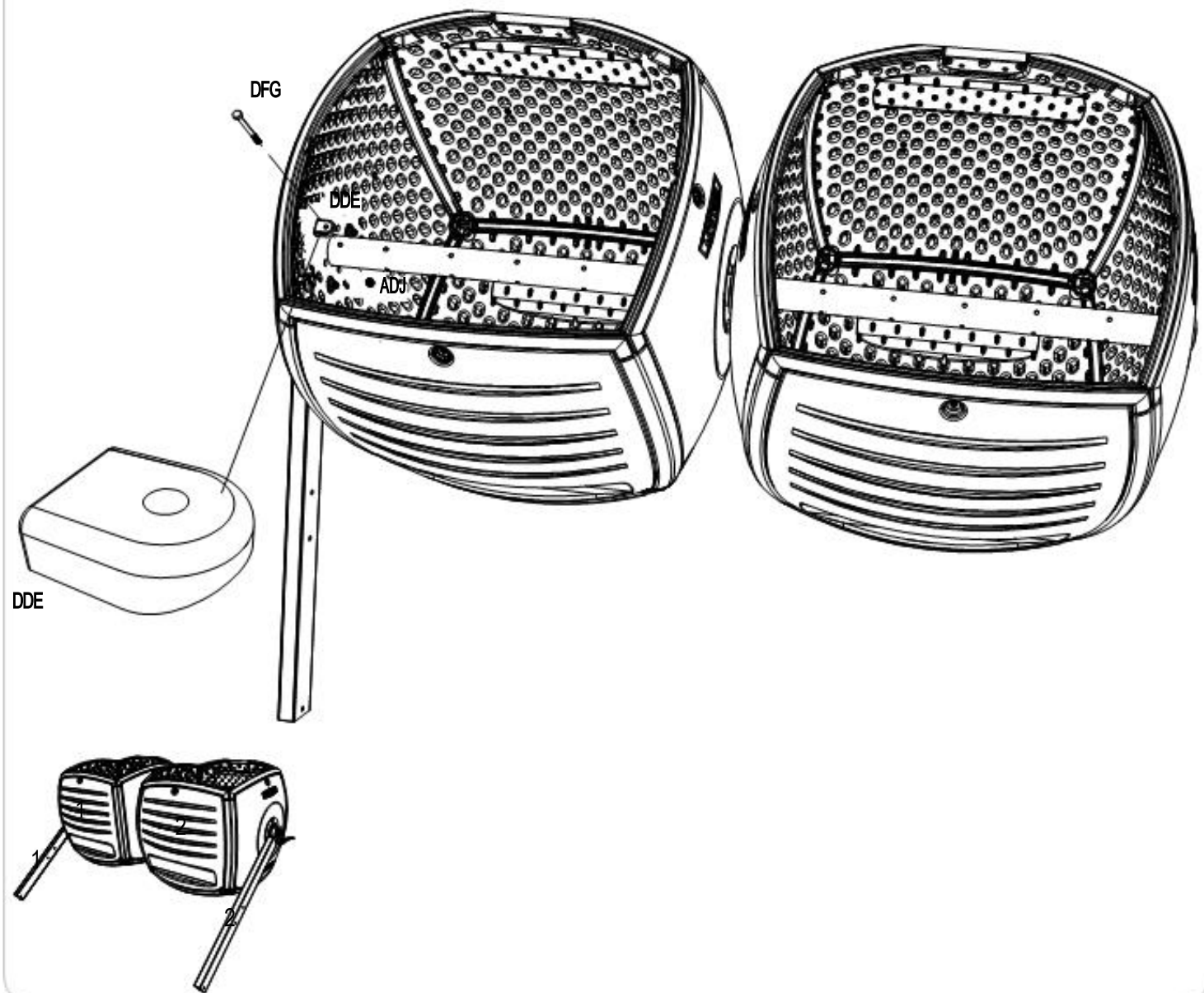



2

1/2"
(12,7 mm) (x2)



BHJ Y



AAN Y

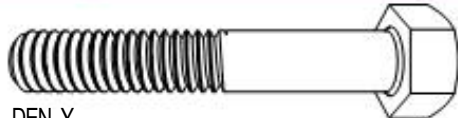

DEN Y



BHO Y



2.16



Nasměrujte dvě trubice DEL a DEM podle obrázku. Použijte elektrickou vrtačku k zasunutí samořezných šroubů BHJ do obou trubic.

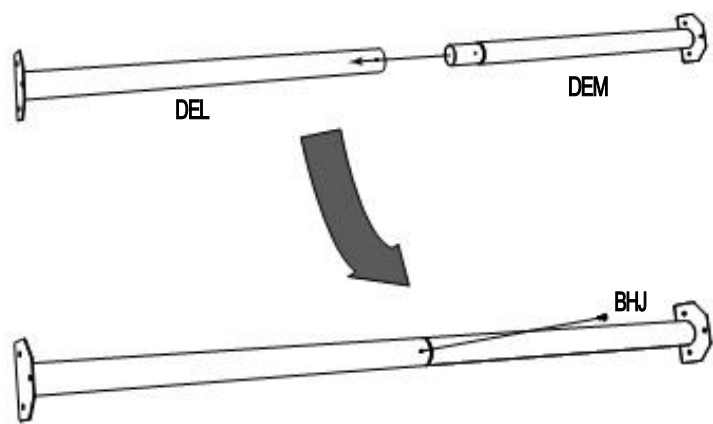

2.17

Spojte dvě přední nohy DEJ se zadními nohami potřebným materiálem.

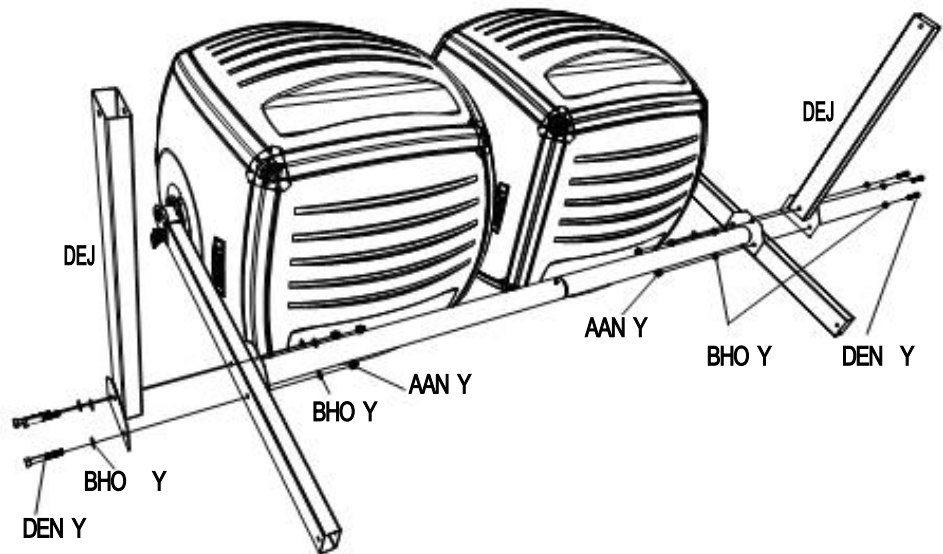



2

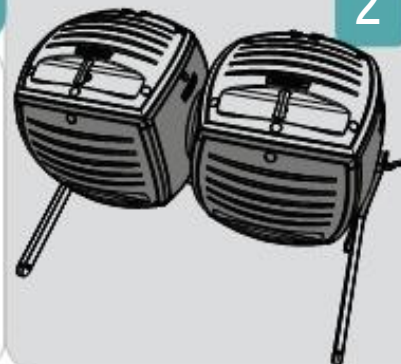

2.18

Vložte čtyři krytky DEO na konce nohou, jak vidíte na obrázku.

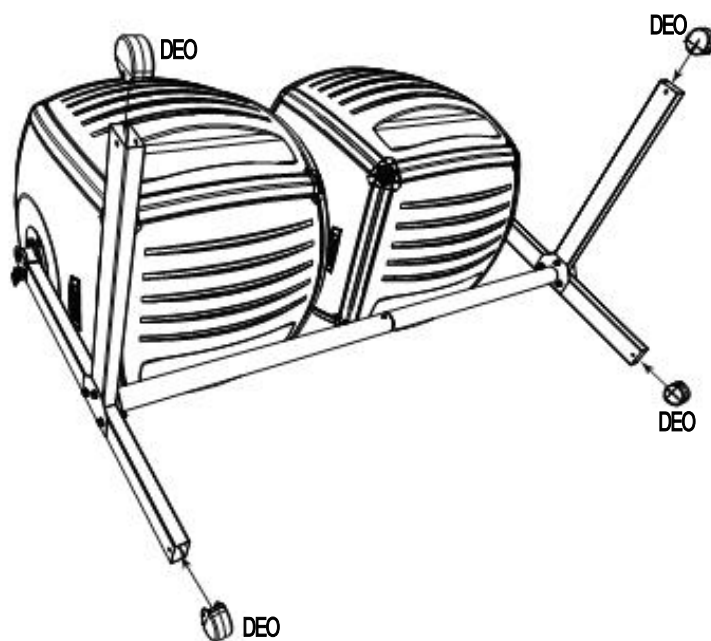

2.19

Otočte kompostér kolmo podle obrázku.

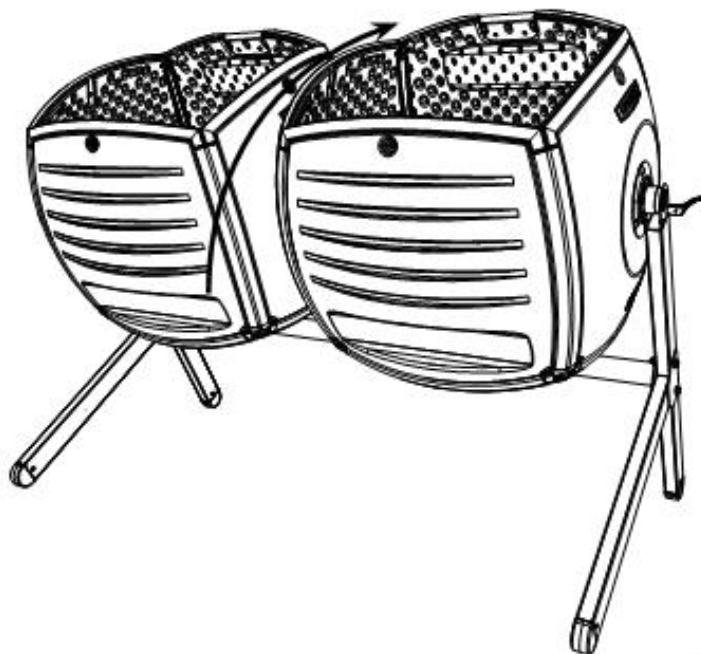



7/16"
(11,1 mm)

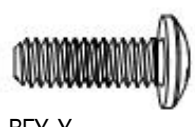

BFY Y



ADJ Y



2.20

Připevněte k pravému bubnu následující díly.

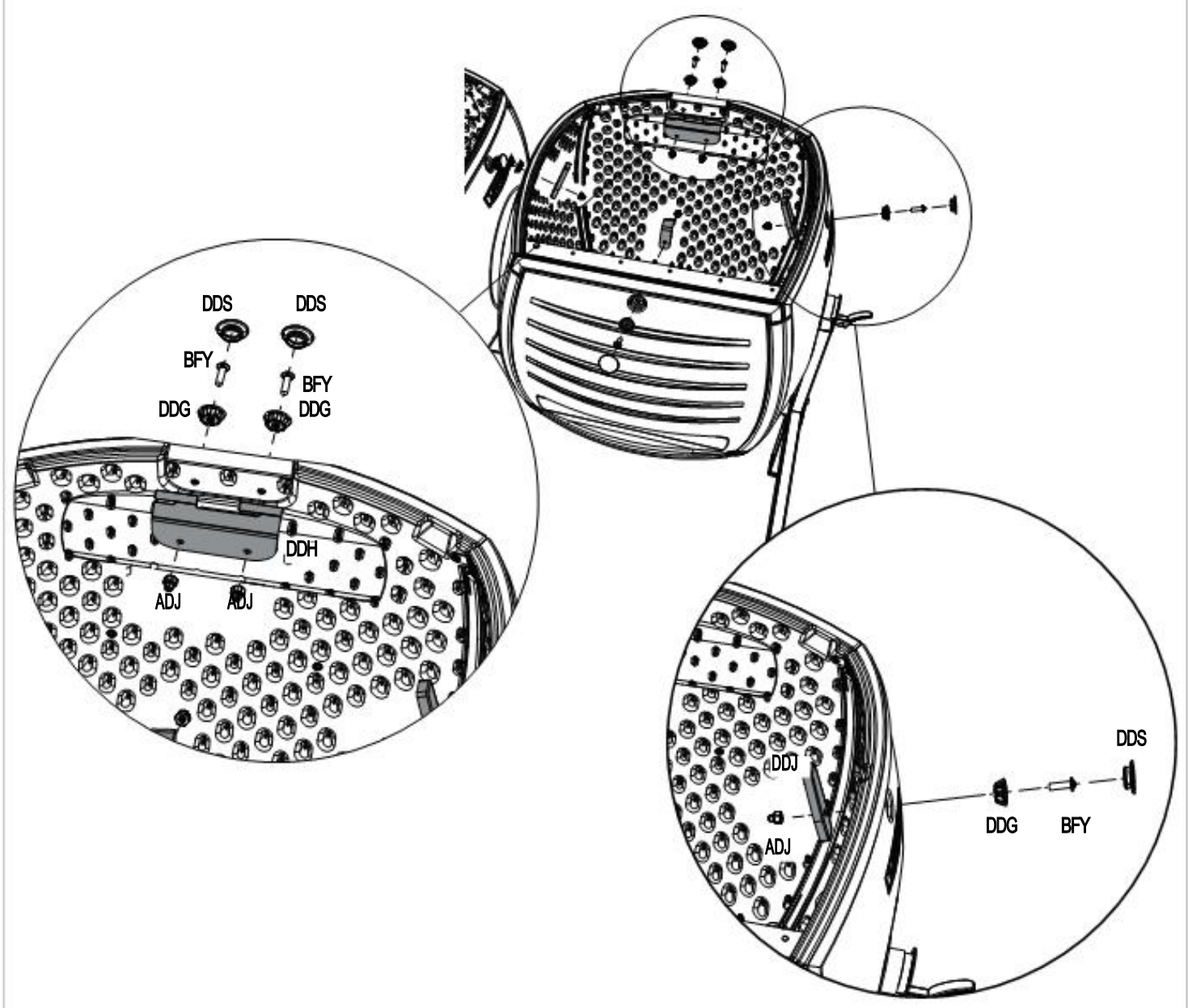



2



7/16"
(11,1 mm)



BFY Y



ADJ Y



2.21

Zopakujte krok 2.20 u následujících míst. Potom zopakujte kroky 2.20 – 2.21 s druhým bubnem.

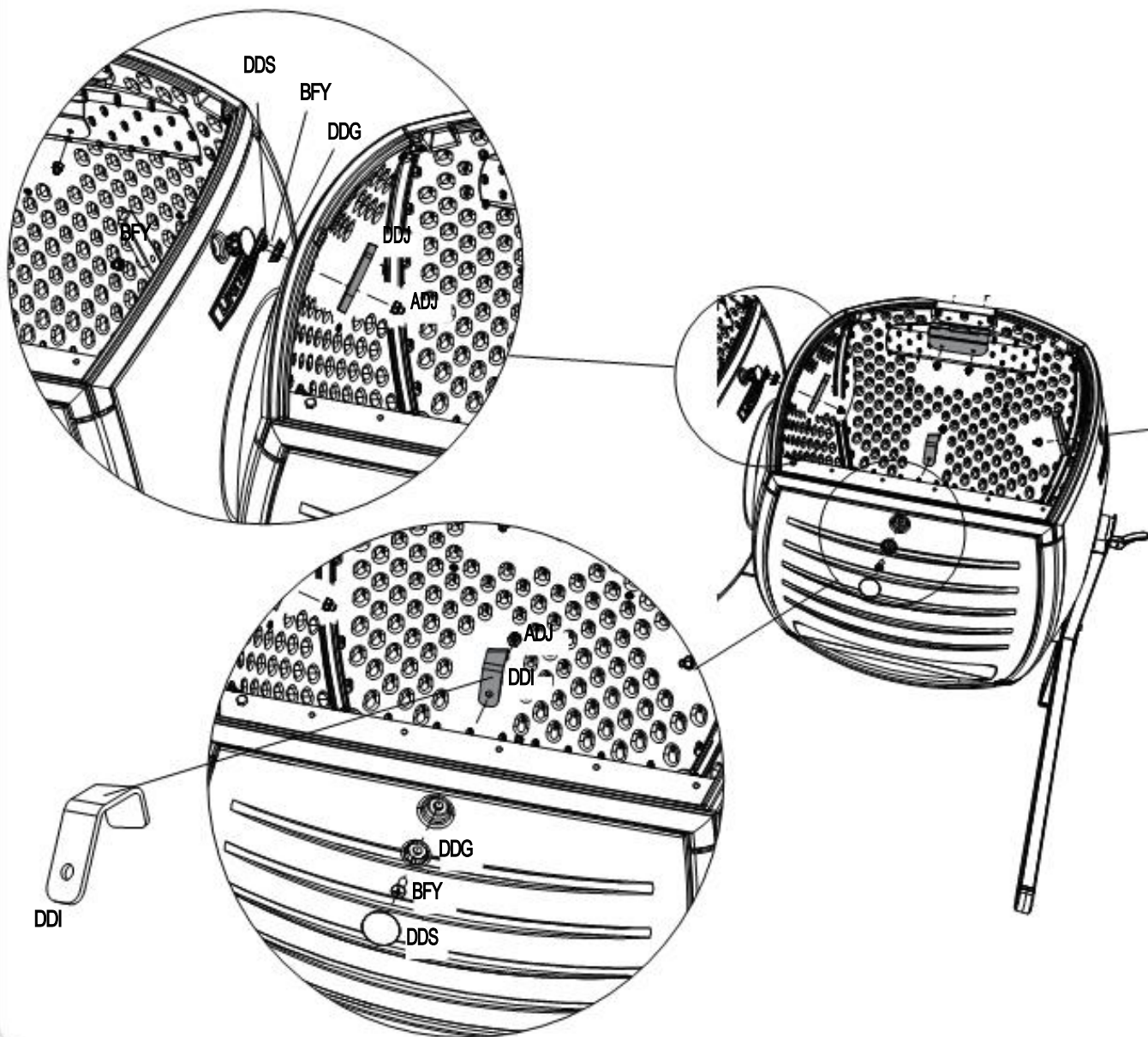



3



DDL Y

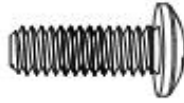

BFY Y



DDN Y

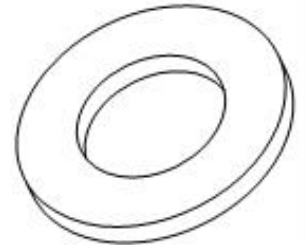

DDM Y



AAN Y



ADJ Y

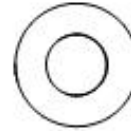

BHO Y



DDO Y

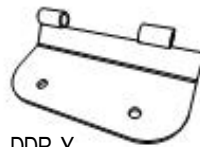

DDR Y

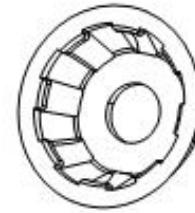

DDG Y



DDK Y

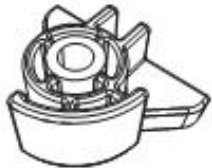

DDP Y



DDQ Y



DDS Y



DEY Y



DDJ Y



DBR Y



1/2" (12,7 mm)



7/16" (11,1 mm)





3



1/2" (12,7 mm) DDL Y

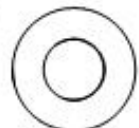

BHO Y



DDL Y

DDN Y



AAN Y

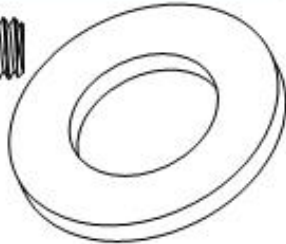

DDM Y

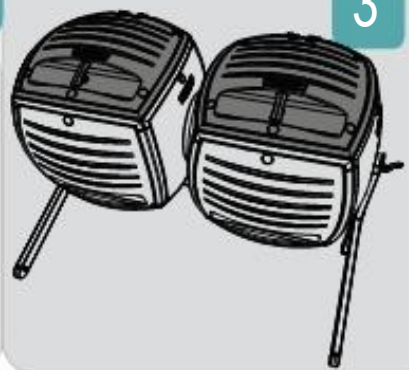

3.1

Připevněte následující díly a součástky k hornímu panelu (víku) DBR.

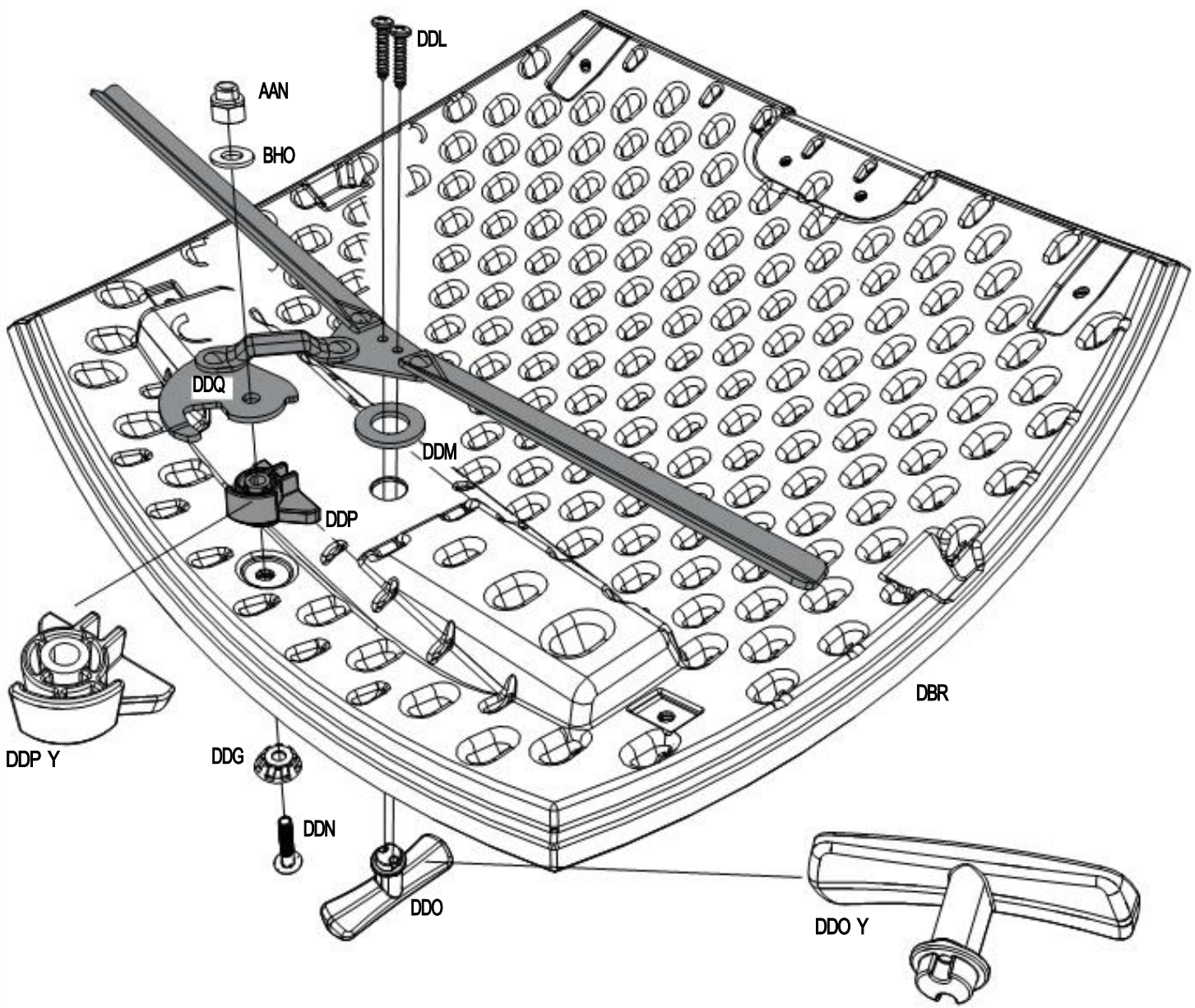



3



ADJ Y



3.2

Vložte matku ADJ do vodítka západky DDK a vycentrujte ji. Tento krok zopakujte také u druhého vodítka.

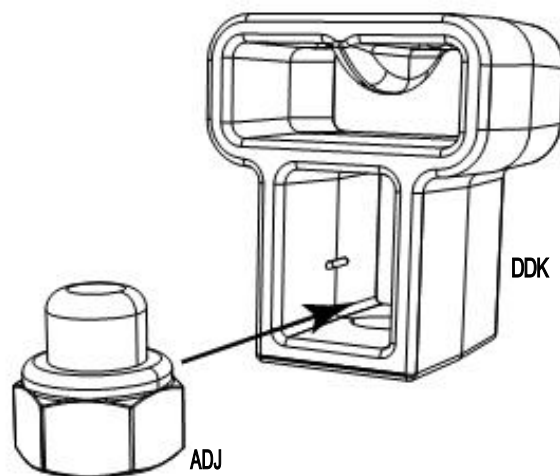

3.3

Zasuňte matku ADJ do DDK a vycentrujte ji. Tento krok zopakujte také u druhého vodítka.

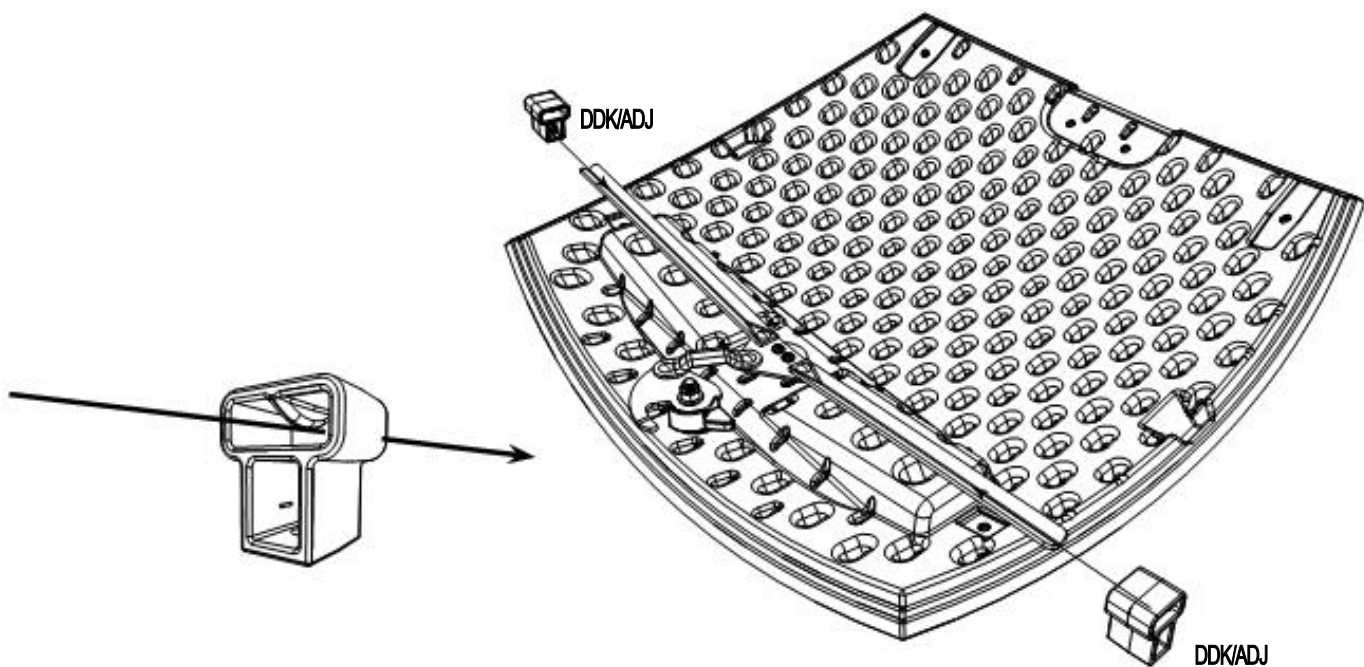



3



7/16" (11,1 mm)

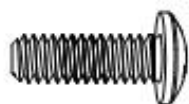

BFY Y



ADJ Y



3.4

Připevněte DDG k víku použitím následujícího hardwaru a součástek.

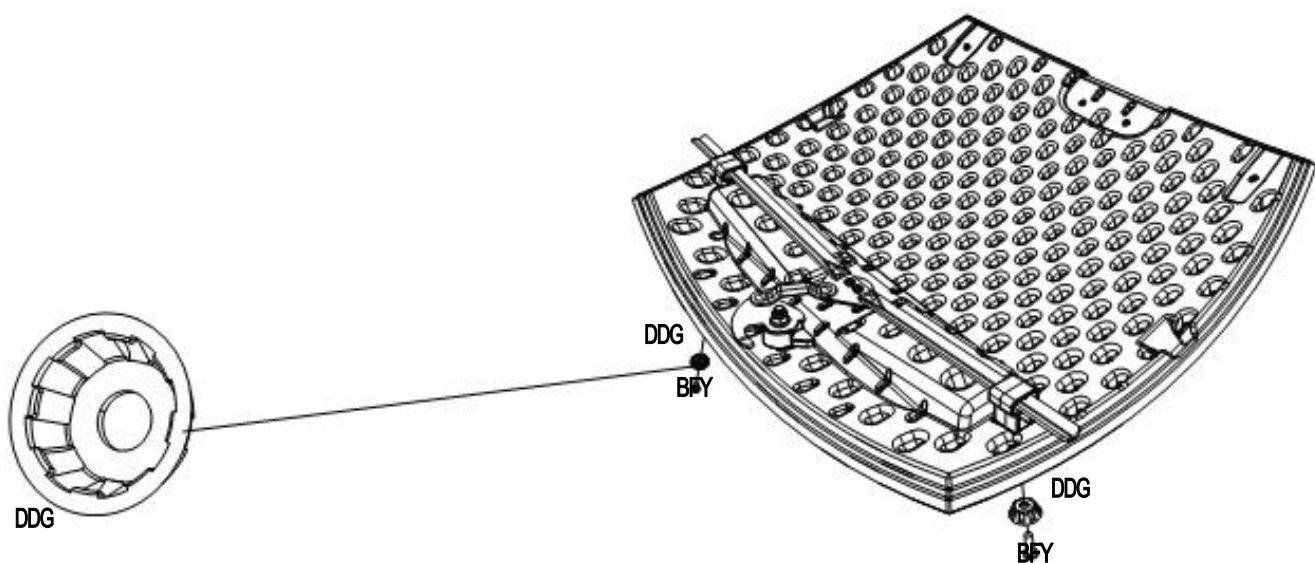

3.5

Připevněte následující díly a součástky k víku.

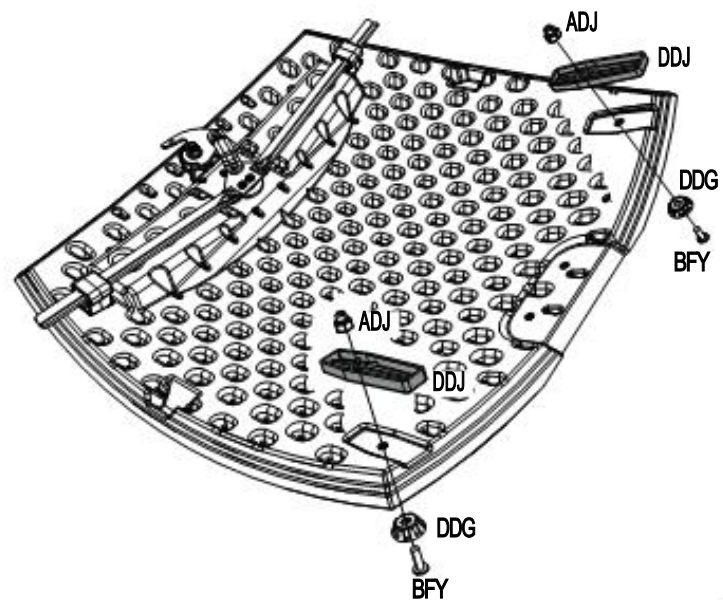



3



7/16" (11,1 mm)



BFY Y



ADJ Y



3.6

Připevněte následující hardware a součástky k víku.

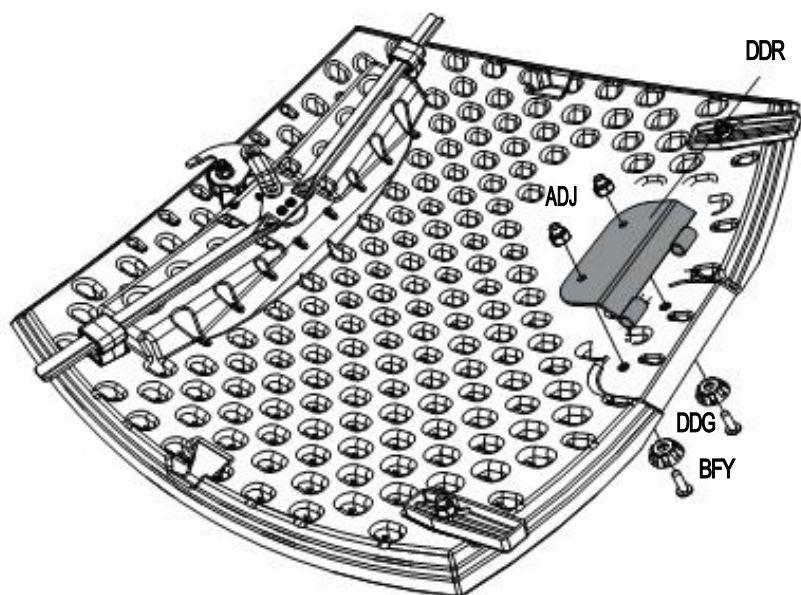

3.7

Zacvakněte zátku DDS na víko. Zopakujte kroky 3.1 – 3.7 také s druhým víkem.

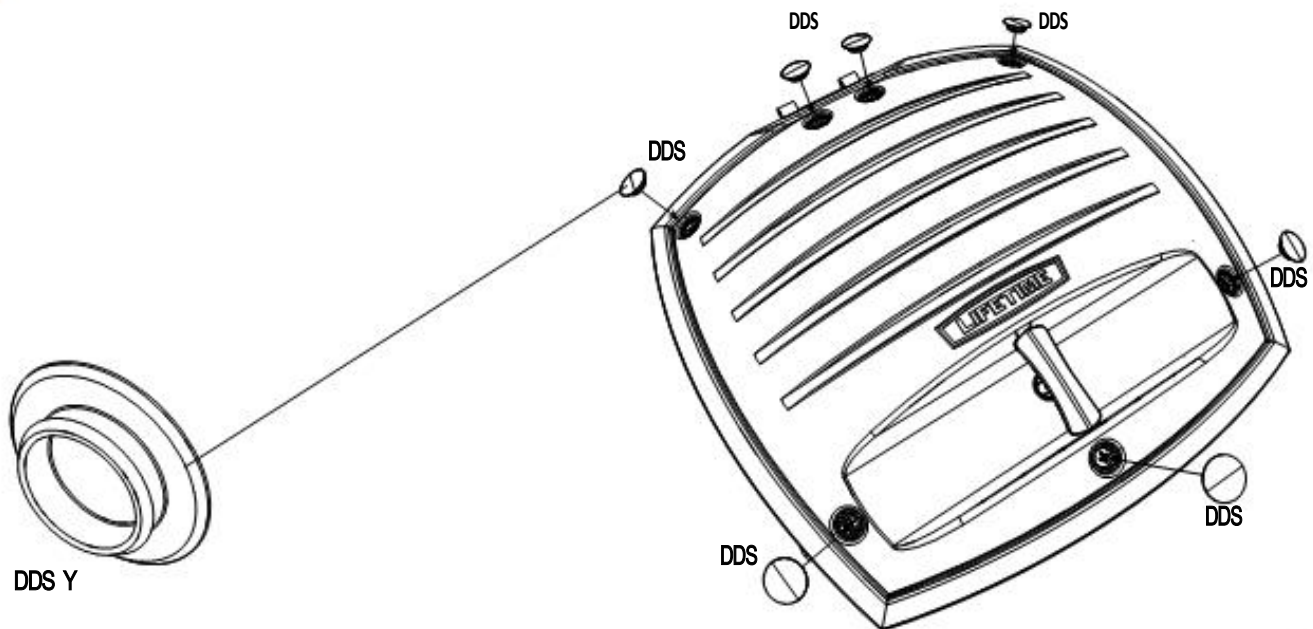



3



3.8

Nasuňte dvě víka na bubny podle obrázku.



3.9

Připevněte svorku DEY na jedno držadlo.

To bude sloužit k odlišení bubnu, který obsahuje nejnovější kompost.

